



Duct Inverter

Installation Manual

New Released

Form: AMKFBNJMFM-200530

ROOFTOP PACKAGE AIR CONDITONER 60HZ R410A 14 SEER



YMFE24BNJMCMO-X

YMFE36BNJMCMO-X

YMFE48BNJMCMS-X

YMFE60BNJMCMS-X

Issue Date
May 30, 2020

TABLE OF CONTENTS

1.0 SAFETY.....	3
1.1 INSPECTION.....	4
1.2 LIMITATIONS.....	4
2.0 INSTALLATION.....	5
2.1 PRE-INSTALLATION.....	5
2.2 CLEARANCE.....	5
2.3 RIGGING AND HANDING.....	5
3.0 DUCTWORK.....	11
4.0 CONDENSATE DRAIN CONNECTION.....	11
4.1 INSTALL DRAIN PIPE.....	12
5.0 FILTERS.....	12
6.0 ELECTRICAL WIRING.....	12
6.1 POWER WIRING.....	12
6.2 GROUNDING.....	13
6.3 CONTROL WIRING.....	13
7.0 AIRFLOW PERFORMANCE.....	17
7.1 AIRFLOW PERFORMANCE DATA.....	17
8.0 SYSTEM OPERATION.....	22
8.1 COMPRESSOR CRANKCASE HEATER.....	22
8.2 PROTECTION.....	22
8.3 THERMOSTAT SIGNALS.....	23
9.0 OPERATION CHECK-UP.....	24
10.0 TROUBLE SHOOTING.....	24

LIST OF TABLES

TABLE 2-1 UNIT CLEARANCE.....	11
TABLE 6-1 14 SEER HEAT PUMP W/WITHOUT ELECTRIC HEAT.....	15
TABLE 6-2 14 SEER PHYSICAL DATA.....	16
TABLE 7-1 DUCT APPLICATION(208V).....	17
TABLE 7-2 DUCT APPLICATION(230V).....	18
TABLE 7-3 &7-4 & 7-5 REFRIGERANT CHARGE FOR A/C SYSTEM.....	20
TABLE 7-6 &7-7 & 7-8 REFRIGERANT CHARGE FOR A/C SYSTEM.....	21
TABLE 8-1 THERMOSTAT SIGNALS.....	23
TABLE 8-2 THERMOSTAT WIRE COLOR.....	23

LIST OF FIGURES

FIG. 2-1 COMPONENT LOCATION.....	6
FIG. 2-2 UNIT DIMENSIONS.....	7
FIG. 2-3 DIMENSIONS Back and Bottom.....	8
FIG. 2-4 UNIT DIMENSIONS.....	9
FIG. 2-5 DIMENSIONS Back and Bottom.....	10
FIG. 6-1 TYPICAL FIELD CONTROL WIRING DIAGRAM.....	14
FIG. 6-2 TYPICAL FIELD POWER WIRING DIAGRAM.....	14
AC SYSTEM WIRING DIAGRAM (24/42/48).....	25
AC SYSTEM WIRING DIAGRAM (30/60).....	26
AC SYSTEM WIRING DIAGRAM (36).....	27

This document is customer property and is to remain with this unit. These instructions do not cover all the different variations of systems nor does it provide for every possible contingency to be met in connection with installation.

All phases of this installation must comply with NATIONAL, STATE and LOCAL CODES. If additional information is required please contact your local distributor.

1.0 SAFETY

When you see the symbols below on the labels or in the manuals, be alert to the potential or immediate hazards of personal injury, property and/or product damage. It is the owner's or installer's responsibility to comply with all safety instructions and information accompanying these symbols.

 **WARNING:** This is a safety alert symbol indicating a potential hazardous situation, which could result in personal injury, property and/or product damage or death.

 **CAUTION:** This is a safety alert symbol indicating a potential hazardous situation, which could result in moderate personal injury, property and/or product damage.

 WARNING
These instructions are intended as an aid to qualified, licensed service personnel for proper installation, adjustment and operation of this unit. Read these instructions thoroughly before attempting installation or operation. Failure to follow these instructions may result in improper installation, adjustment, service or maintenance possibly resulting in fire, electrical shock, property damage, personal injury or death.

 WARNING
The manufacturer's warranty does not cover any damage or defect to the heat pump caused by the attachment or use of any components, accessories or devices (other than those authorized by the manufacturer) into, onto or in conjunction with the heat pump. You should be aware that the use of unauthorized components, accessories or devices may adversely affect the operation of the heat pump and may also endanger life and property. The manufacturer disclaims any responsibility for such loss or injury resulting from the use of such unauthorized components, accessories or devices.

 WARNING
Disconnect all power to the unit before starting maintenance. Failure to do so can result in severe electrical shock or death.

 WARNING
Do not, under any circumstances, connect return ductwork to any other heat producing device such as a fireplace insert, stove, etc. Unauthorized use of such devices may result in fire, carbon monoxide poisoning, explosion, property damage, severe personal injury or death.

 WARNING
The unit must be permanently grounded. A grounding lug is provided. Failure to ground this unit can result in fire or electrical shock causing property damage, severe personal injury or death.



WARNING

Only electric heater kits supplied by this manufacturer as described in this publication have been designed, tested, and evaluated by a nationally recognized safety testing agency for use with this unit. Use of any other manufactured electric heaters installed within this unit may cause hazardous conditions resulting in property damage, fire, body injury or death.



WARNING

Proposition 65: This appliance contains fiberglass insulation. Respirable particles of fiberglass are known to the state of California to cause cancer.



CAUTION

Only use this unit in well-ventilated spaces and ensure that there are no obstructions that could impede the airflow into and out of the unit.

Do not use this unit in the following locations:

- Locations with mineral oil.
- Locations with saline atmospheres, such as seaside locations.
- Locations with sulphurous atmospheres, such as near natural hot springs.
- Where high voltage electricity is present, such as in certain industrial locations.
- On vehicles or vessels, such as trucks or ferry boats.
- Where exposure to oily or very humid air may occur, such as kitchens.
- In proximity to sources of electromagnetic radiation, such as high-frequency transmitters or other high strength radiation devices.



CAUTION

A manufactured (mobile) home installation must conform with the Manufactured Home Construction and Safety Standard, Title 24 CFR, Part 3280, or when this Standard is not applicable, the Standard for Manufactured Home Installations (Manufactured Home Sites, Communities and Set-Ups), ANSI/NCS A225.1, and/or MH Series Mobile Homes, CAN/CSA Z240.

1.1 INSPECTION

As soon as unit is received, it should be inspected and noted for possible shipping damage during transportation. It is carrier's responsibility to cover the cost of shipping damage. Manufacturer or distributor will not accept the claims from dealer for any transportation damage.

1.2 LIMITATIONS

Refer to *Fig. 2-2, 2-3, 2-4, 2-5* for unit physical data and to *Table 6-1 & 6-2* for electrical data. If components are to be added to a unit they must meet local codes, they are to be installed at the dealer's and /or the customer's expense. Size of unit for proposed installation should be based on heat loss / heat gain calculations made in accordance with industry recognized procedures identified by the Air Conditioning Contractors of America.

2.0 INSTALLATION

2.1 PRE-INSTALLATION

Before installation, carefully check the following:

1. Unit should be installed in accordance with national and local safety codes, including but not limit to ANSI/NFPA No. 70 or Canadian Electrical Code Part 1, C22.1, local plumbing and wastewater codes and any other applicable codes.
2. For rooftop installation, be sure the structure has enough strength to support the weight of unit. Unit should be installed on roof curb and leveled.
3. For ground level installation, a level slab should be used.
4. Condenser airflow should not be restricted.
5. On applications when a roof curb is used, the unit must be positioned on the curb so the front of the unit is tight against the curb.

2.2 CLEARANCE

All units require certain clearance for proper operation and service. Refer to *Table 2-1* for the clearances required for construction, servicing and proper unit operation.

2.3 RIGGING AND HANDING

Exercise care when moving the unit. Do not remove any packaging until the unit is near the place of installation. Rig the unit by attaching chain or cable slings to the lifting holes provided in the base rails. Spreader bars, whose length exceeds the largest dimension across the unit, **MUST** be used across the top of the unit.



CAUTION

Before lifting, make sure the unit weight is distributed equally on the rigging cables so it will lift evenly.

Units may be moved or lifted with a forklift. Slotted openings in the base rails are provided for this purpose.



CAUTION

All panels must be secured in place when the unit is lifted. The condenser coils should be protected from rigging cable damage with plywood or other suitable material.



WARNING

Check the electric wire, water and gas pipeline layout inside the wall, floor and ceiling before installation. Do not implement drilling unless confirm safety with the user, especially for the hidden power wire. An electroprobe can be used to test whether a wire is passing by at the drilling location, to prevent physical injury or death caused by insulation broken cords.



WARNING

Check the power supply before installation. Ensure that the power supply must be reliably grounded following local, state and National Electrical Codes. If not, for example, if the ground wire is detected charged, installation is prohibited before it is rectified. Otherwise, there is a risk of fire and electric shock, causing physical injury or death.

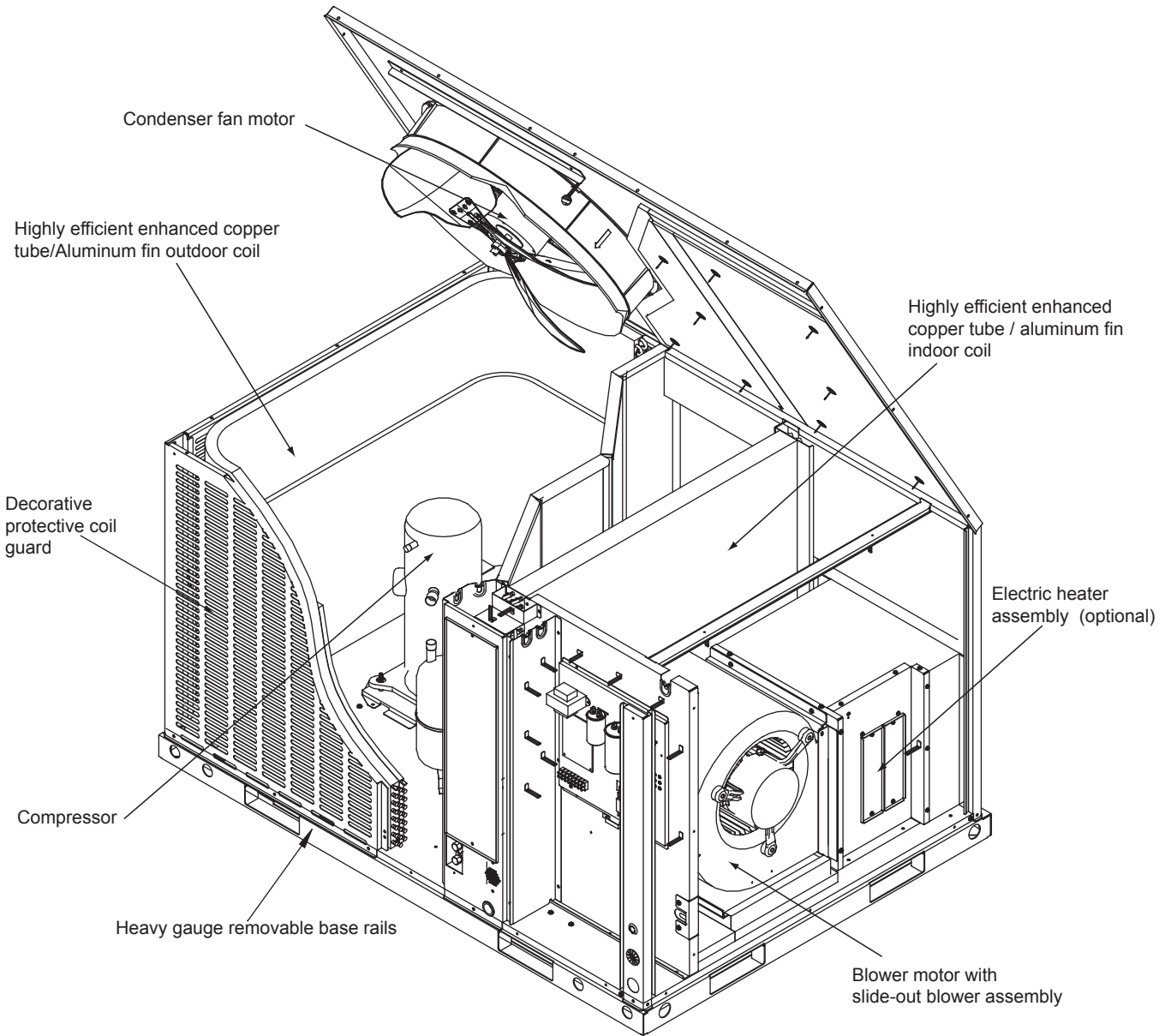

Fig. 2-1 Component Location

* The above figure for reference purpose only.

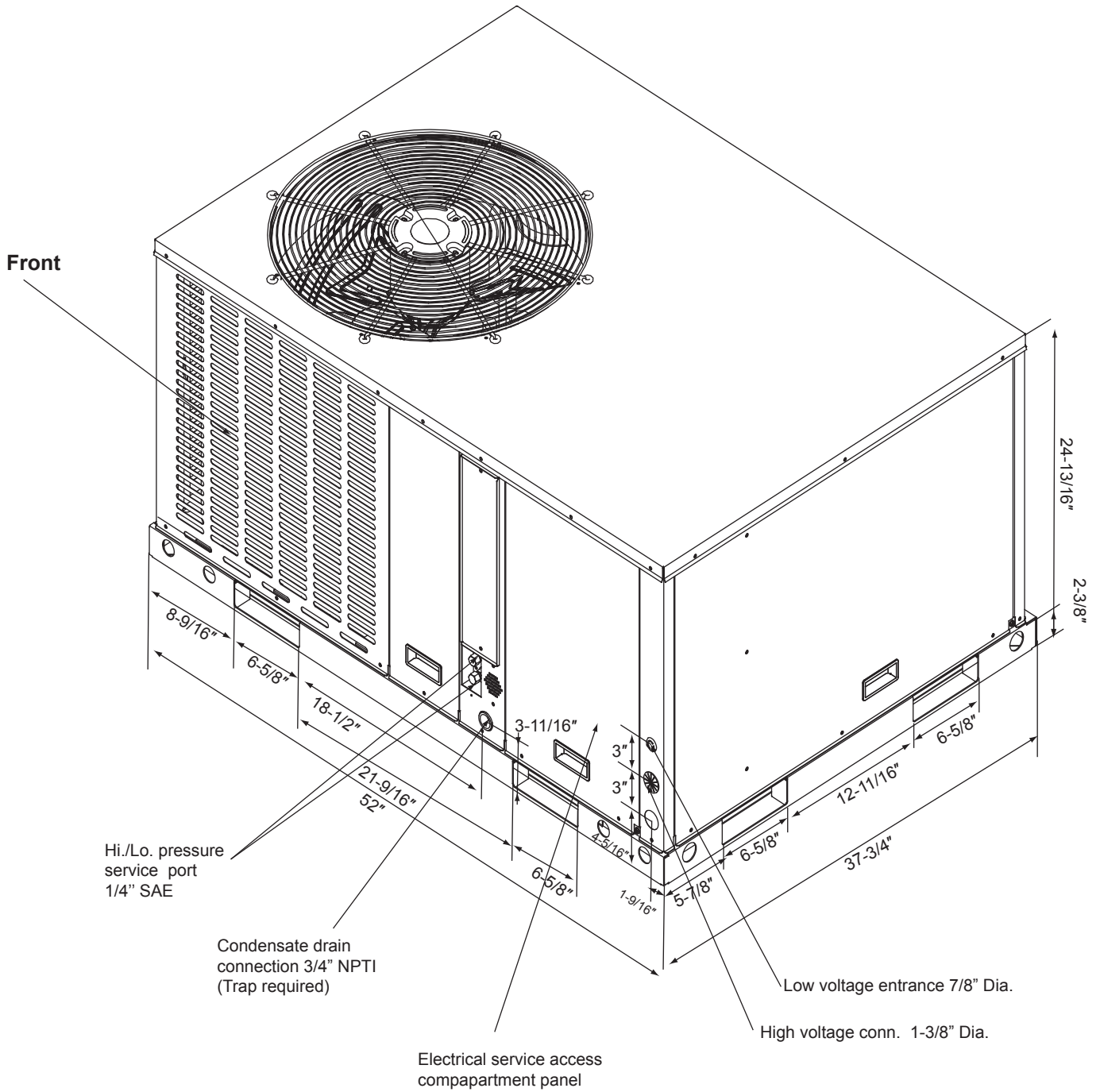

Fig. 2-2 Unit Dimensions

* The above figure for reference purpose only.

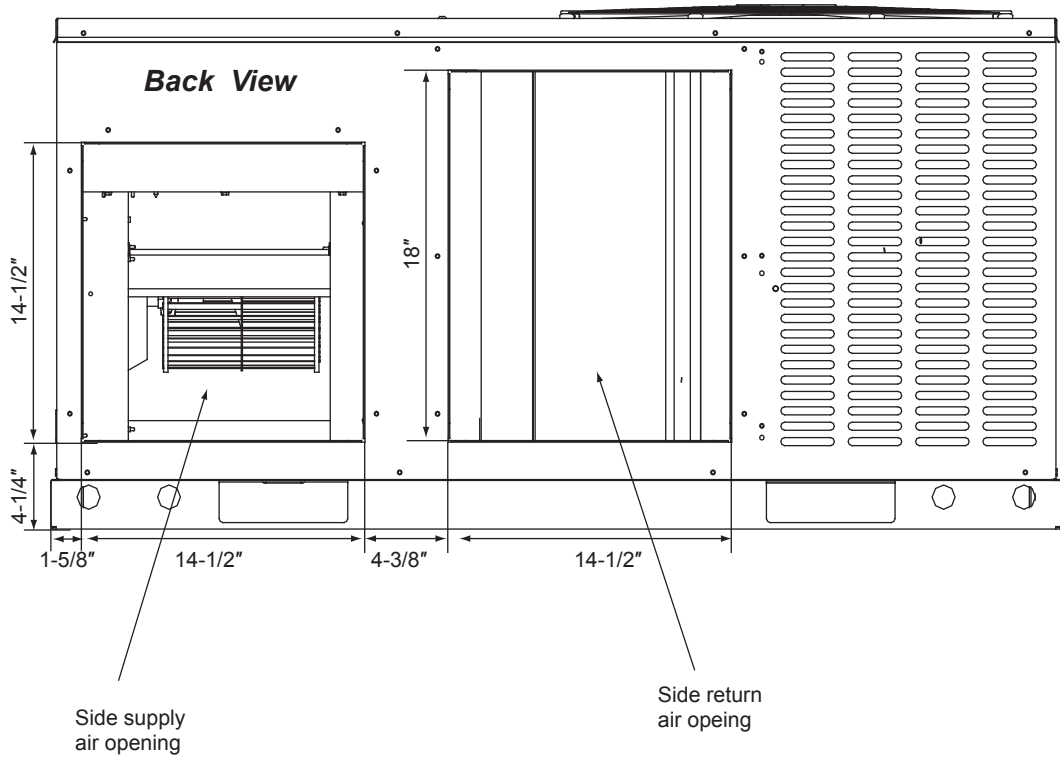
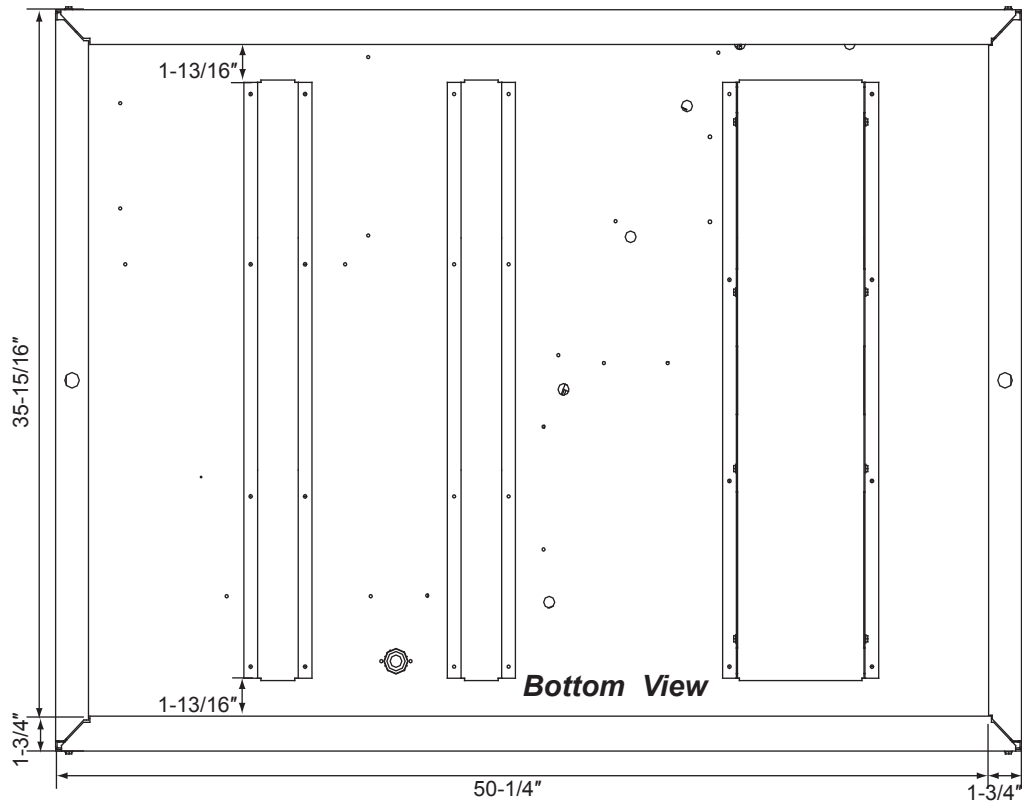

Fig. 2-3 Dimensions Back and Bottom

* The above figure for reference purpose only.

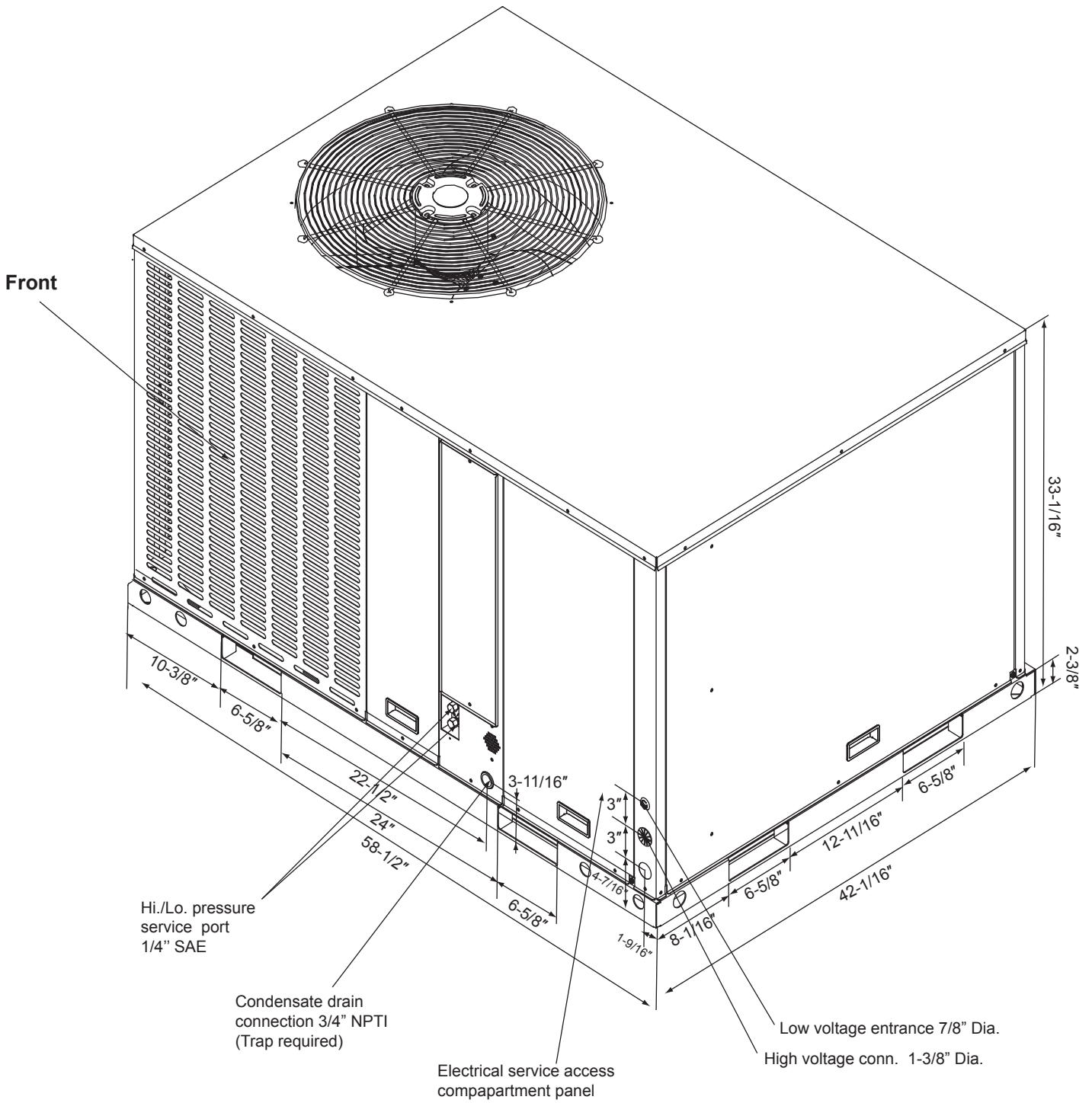

Fig. 2-4 Unit Dimensions

* The above figure for reference purpose only.

Unit size: 048, 060

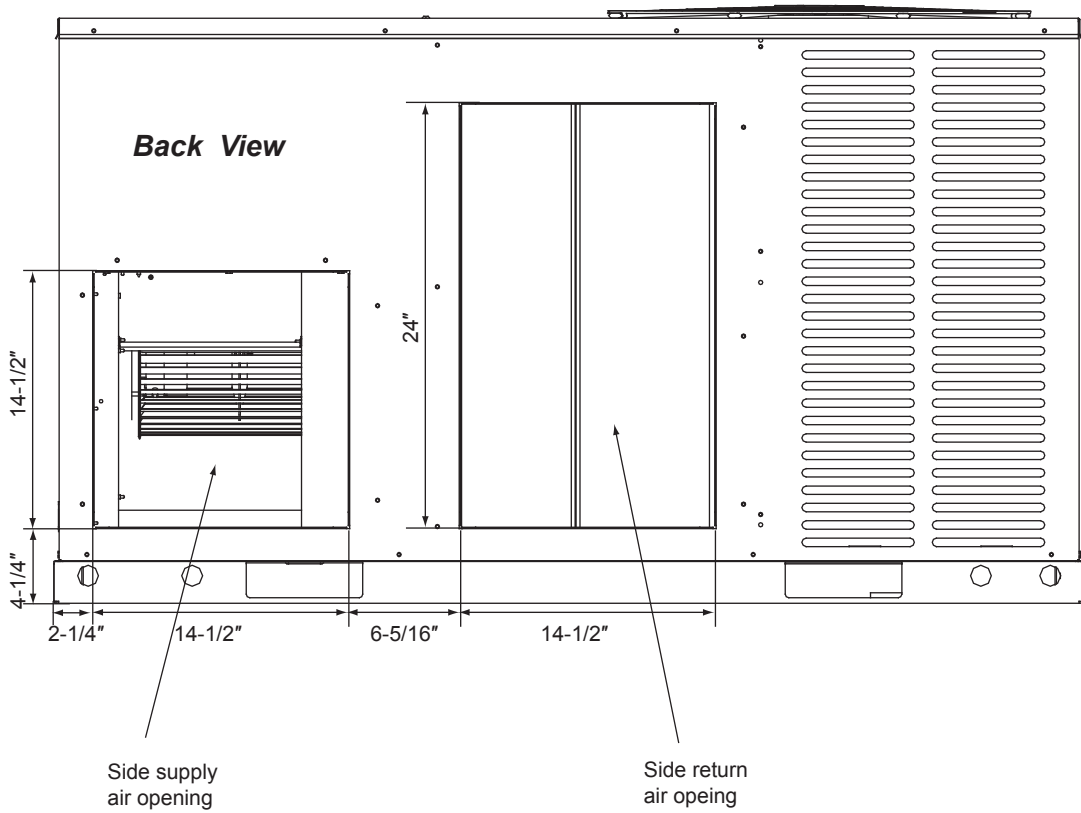
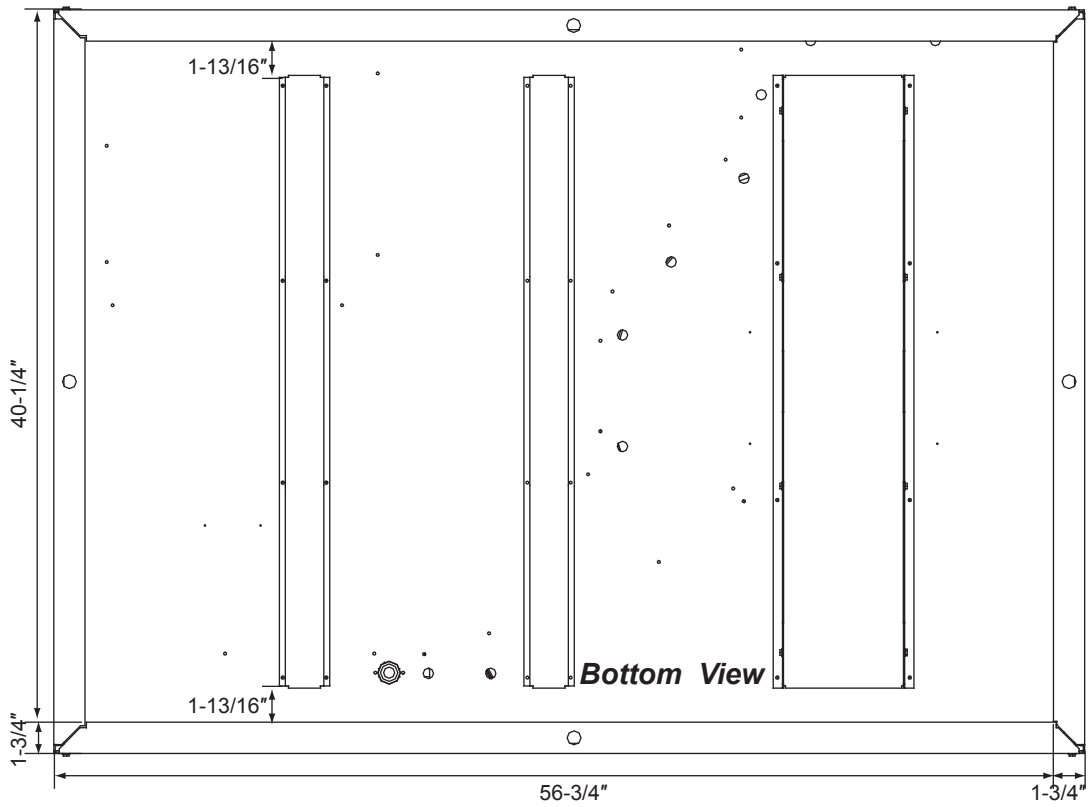

Fig. 2-5 Dimensions Back and Bottom

* The above figure for reference purpose only.

Table 2-1: Unit Clearance

Direction	Distance (in.)	Direction	Distance (in.)
Top ¹	60	Right	12
Front	30	Left	24
Rear	18 ²	Bottom ³	0

Duct clearance: 1 inch clearance for all sides of air supply duct.

1. Units must be installed outdoors. Over hanging structure or shrubs should not obscure condenser air discharge outlet.

2. The minimum clearance without economizer/fresh air damper. For distance with economizer/fresh air damper, please refer to the installation instructions provided with the accessory.

3. Units may be installed on combustible floors made from wood or class A, B or C roof covering materials.



NOTE

For units applied with a roof curb, the minimum clearance may be reduced from 1 inch to 1/2 inch between combustible roof curb material and this supply air duct.



NOTE

A unit with electric heaters with an inlet or outlet duct that penetrates the building structure supporting the unit shall be provided with a mounting base of noncombustible material so designed that, after the unit is installed, there will be no open passages through the supporting structure that would permit flame or hot gases from a fire originating in the space below the supporting structure to travel to the space above that structure. If the unit is intended to be installed on a supporting structure of combustible material, the base shall be so designed that the required clearance will be maintained between the supporting structure and the unit, plenum, and attached duct. Spacers necessary to provide required clearances shall be attached to the unit mounting base, and shall extend not less than 76 mm (3 in.) below the upper surface of the supporting structure, except that, in a unit designed for use only in a mobile home, the distance shall be not less than 19 mm (3/4 in.).

3.0 DUCTWORK

Ductwork should be sized and installed by the installing contractor in accordance with the Manual D from the Air Conditioning Contractors of America, and all national, state and local codes.



NOTE

On ductwork exposed to outside air space, use at least 2" of insulation and a vapor barrier. Flexible joint may be used to reduce noise.

A closed return duct system shall be used. This shall not preclude use of economizers or ventilation air intake. Flexible joints may be used in the supply and return duct work to minimize the transmission of noise.



CAUTION

When fastening duct work to the side duct flanges on the unit, insert the screws through the duct flanges only. DO NOT insert the screws through the casing. Outdoor duct work must be insulated and waterproofed.



NOTE

Be sure to note supply and return openings. Refer to Fig. 2-3 and 2-5 for information concerning supply and return air duct openings.

4.0 CONDENSATE DRAIN CONNECTION

Consult local codes for special requirements.

To provide extra protection from water damage, install an additional drain pan, provided by installer, under the entire unit with a separate drain line.

Manufacturer will not be responsible for any damages due to the failure to follow these requirements.

4.1 INSTALL DRAIN PIPE

1. Use the provided female NPT threaded fitting for outside connection and make sure that drain holes are not blocked.
2. Insulation may be needed for drain line to prevent sweating.
3. Drain pan has two drain connections on each side to provide flexibility of connection and drainage. Make sure proper pitch and plugging if second connection is not used.
4. Use a sealing compound on male pipe threads. Install the condensate drain line (NPT) to spill into an open drain.
5. Ensure a trap is included in the condensate drain line.

5.0 FILTERS

Units are shipped without a filter or filter racks. It is the responsibility of the installer to secure a filter in the return air ductwork or install a filter/frame Kit.

Filter must always be used and must be kept clean. Dirty filters may cause insufficient air delivery, decreasing unit efficiency and increasing operation costs and wear-and tear on the unit and controls.

Filters should be checked monthly; this is especially important since this unit is used for both heating and cooling.

6.0 ELECTRICAL WIRING

Field wiring must comply with the National Electric Code (NEC) or Canadian Electrical Code (CEC) and any applicable local ordinance.



WARNING

Disconnect all power to unit before installing or servicing. More than one disconnect switch may be required to de-energize the equipment. Hazardous voltage can cause severe personal injury or death.

6.1 POWER WIRING

1. Proper electrical power should be available at unit. Voltage tolerance should not be over 10% from rating voltage.
2. If any of the wire must be replaced, replacement wire must be the same type as shown in nameplate, wiring diagram and electrical data sheet.
3. Install a branch circuit disconnect of adequate size to handle starting current, located within sight of, and readily accessible to the unit.
4. ELECTRIC HEATER - If the Electric Heater is installed, unit may be equipped with 30~60A. circuit breakers or fuse. These breaker(s) protect the internal wiring in the event of a short circuit and serve as a disconnect. Circuit breakers installed within the unit do not provide over-current protection of the supply wiring and therefore may be sized larger than the branch circuit protection.
 - Supply circuit power wiring must be 221 °F minimum copper conductors only. See Electrical Data in this section for ampacity, wire size and circuit protector requirements. Supply circuit protective devices may be either fuses or “HACR” type circuit breakers.
 - 1-3/8” knockouts inside the cabinet are provided for connection of power wiring to electric heater.
 - Power wiring is connected to the power terminal block in unit electric cabinet.

See Electrical Heater Installation Instruction for details.

6.2 GROUNDING

	WARNING
The unit must be permanently grounded. Failure to do so can result in electrical shock causing personal injury or death.	

- The unit must be electrically grounded in accordance with local codes or the national electric code.
- Grounding may be accomplished by attaching ground wire(s) to ground lug(s) provided in the unit wiring compartment.

6.3 CONTROL WIRING

IMPORTANT: Class 2 low voltage control wiring SHOULD NOT be run in conduit with main power wiring and must be separated from power wiring, unless class 1 wire of proper voltage rating is used.

- Low voltage control wiring should be 18 AWG color-coded. For lengths longer than 50 ft, 16 AWG wire should be used.
- Two 7/8” holes can be used for control wires going into the unit, one on left side and one at the bottom.
- Make sure, after installation, separation of control wiring and power wiring has been maintained.

Thermostat should be mounted on an inside wall about 58” from floor and will not be affected by unconditioned air, sun and/or heat exposure. Follow the instruction carefully because there are many wiring requirements. See Fig. 6-1 ~ 2, Table 6-1.

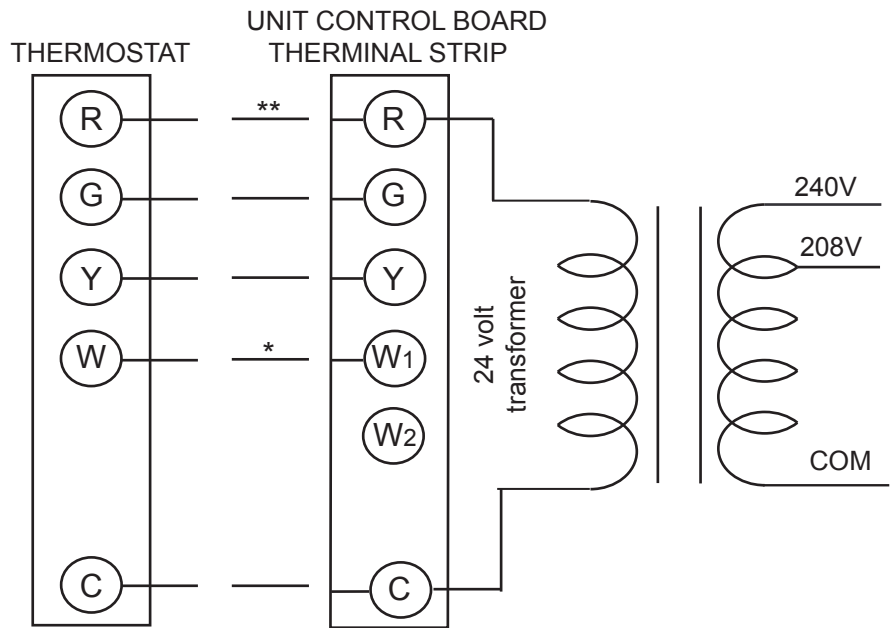

Fig. 6-1 Typical Field Control Wiring Diagram

- ** Minimum wire size of 18 AWG wire should be used for all field installed 24 volt wire.
- * Only required on units with supplemental electric heat.

	CAUTION
Label all wire prior to disconnection when servicing controls. Wiring errors can cause improper and dangerous operation. Verify proper operation after servicing.	

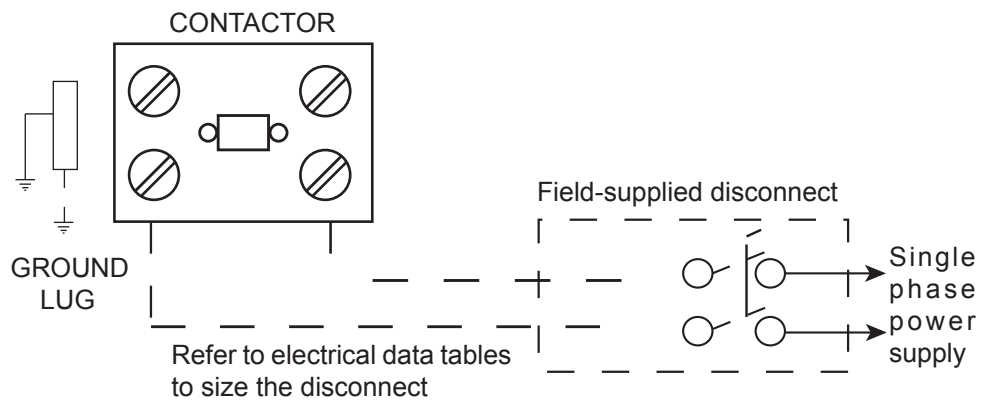

Fig. 6-2 Typical Field Power Wiring Diagram

Table 6-1: 14 SEER W/Without Electric Heat

Size (Tons)	Volt	Compressors (each)			OD Fan Motors (each)	Supply Blower Motor	Unit Circuit		Heater Circuit					
		RLA	LRA	MCC			MCA1 (Amps)	Max Fuse2/ Breaker3 Size(Amps)	Model	kW	Stages	Amps	MCA1 (Amps)	Max Fuse2/ Breaker3 Size(Amps)
24 (2.0)	208/230-1-60	8.45A	34.8A	14.87A	0.68A	2.46A	13.7	20	EHK-05G	3.8/5	1	18.1/20.8	23/26	25/30
									EHK-08G	5.6/7.5	1	27.1/31.3	34/39	35/40
									EHK-10G	7.5/10	1	36.1/41.7	45/52	45/60
36 (3.0)	208/230-1-60	13.0A	75A	22.9A	1.0A	4.1A	21.4	30	EHK-05G	3.8/5	1	18.1/20.8	23/26	25/30
									EHK-08G	5.6/7.5	1	27.1/31.3	34/39	35/40
									EHK-10G	7.5/10	1	36.1/41.7	45/52	45/60
48 (4.0)	208/230-1-60	17.3A	108A	28.5A	1.67A	3.6A	26.9	40	EHK-05G	3.8/5	1	18.1/20.8	23/26	25/30
									EHK-08G	5.6/7.5	1	27.1/31.3	34/39	35/40
									EHK-10G	7.5/10	1	36.1/41.7	45/52	45/60
60 (5.0)	208/230-1-60	21.5A	125A	34.3A	1.67A	6.0A	34.6	50	EHK-15G	11.3/15	2	54.2/62.5	68/78	70/80
									EHK-20G	15/20	2	72.2/83.3	90/104	90/110
									EHK-05G	3.8/5	1	18.1/20.8	23/26	25/30
									EHK-08G	5.6/7.5	1	27.1/31.3	34/39	35/40
									EHK-10G	7.5/10	1	36.1/41.7	45/52	45/60
									EHK-15G	11.3/15	2	54.2/62.5	68/78	70/80
									EHK-20G	15/20	2	72.2/83.3	90/104	90/110

024/030: Rotary compressor
036/042/048/060: Scroll compressor

1. Minimum Circuit Ampacity.
2. Maximum Over Current Protection per Standard UL 1995.
3. Fuse or HACR circuit breaker size installed at factory or field installed.

Table 6-2: 14 SEER Physical Data

Component	Models			
	24	36	48	60
Nominal Tonnage	2.0	3.0	4.0	5.0
ARI COOLING PERFORMANCE				
Gross Capacity @ ARI A point (Btu)	23,717	35,770	48,411	58,911
ARI net capacity (Btu)	22,800	34,200	46,500	57,000
EER	11	11	11.5	11.5
SEER	14	14	14	14
Nominal CFM	800	1220	1600	2000
System power (kW)	2.07	3.11	4.04	4.96
Refrigerant type	R410A	R410A	R410A	R410A
Refrigerant charge (lb-oz)	4-6	4-10	6-3	6-4
DIMENSIONS (Inches)				
Length	52	52	58-1/2	58-1/2
Width	37-3/4	37-3/4	42-1/16	42-1/16
Height	24-13/16	24-13/16	33-1/16	33-1/16
OPERATING WT. (lbs)	331	337	459	467
COMPRESSORS				
Type	Rotary	Rotary	Scroll 1-spд	Scroll 1-spд
Quantity	1	1	1	1
CONDENSER COIL DATA				
Face area (Sq. Ft)	9.79	9.79	15.54	15.54
Rows	2.5	2.5	2	2
Fins per inch	20	21	21	21
Tube diameter(inch)	3/16	3/16	3/16	3/16
Circuitry type	interlaced	interlaced	interlaced	interlaced
EVAPORATOR COIL DATA				
Face area (Sq. Ft)	3.63	3.63	6.43	6.43
Rows	4	4	4	3
Fins per inch	17	17	17	17
Tube diameter(inch)	9/32	9/32	9/32	9/32
Circuitry type	interlaced	interlaced	interlaced	interlaced
Refrigerant control	Orifice	Orifice	Orifice	Orifice
CONDENSER FAN DATA				
Fan diameter (inch)	22	22	23-5/8	23-5/8
Type	Prop	Prop	Prop	Prop
Drive type	Direct	Direct	Direct	Direct
No. speeds	1	1	1	1
Number of motors	1	1	1	1
Motor HP each	1/8	1/6	1/3	1/3
RPM	1075	825	1075	1075
Nominal total CFM	1960	2565	3960	3960
DIRECT DRIVE EVAP FAN DATA				
Quantity	1	1	1	1
Fan Size (Inch)	10x9	10x9	11x10-5/8	11x10-5/8
Type	Centrifugal	Centrifugal	Centrifugal	Centrifugal
No. speeds	3	3	3	3
Motor HP each	1/4	1/2	3/4	3/4
RPM	1075	1075	1075	1075
Motor frame size	48	48	48	48
FILTERS				
(No.) Size Recommended in.	(1) 22x14x1	(1) 22x14x1	(1) 22x14x1	(1) 22x14x1

7.0 AIRFLOW PERFORMANCE

Airflow performance data is based on cooling performance with a coil and no filter in place. Use this performance table for appropriate unit size, external static applied to unit and allow operation within the minimum and maximum limits shown in table below for both cooling and electric heat operation.

7.1 AIRFLOW PERFORMANCE DATA

Table 7-1 Duct Application(208v)

Model Number	Motor Speed	CFM(L/S)(Watts)								
		External Static Pressure-Inches W.C.[kPa]								
		0[0]	0.1[.02]	0.2[.05]	0.3[.07]	0.4[.10]	0.5[.12]	0.6[.15]	0.7[.17]	
24	Low	CFM(L/S)	756(357)	706 (333)	654 (309)	600(283)				
		RPM	460	553	638	710				
		Watts	161	159	156	152				
		Amps	0.78	0.77	0.75	0.73				
	Middle	CFM(L/S)				842(397)	782(369)	718(339)	625(295)	
		RPM				776	831	884	930	
		Watts				228	220	213	203	
		Amps				1.1	1.06	1.03	0.99	
	High	CFM(L/S)						889(419)	805(380)	693(327)
		RPM						929	970	1004
		Watts						280	266	253
		Amps						1.37	1.32	1.26
36	Low	CFM(L/S)	1170(525)	1143(539)	1110(524)	1070(505)	1021(428)			
		RPM	694	752	806	859	902			
		Watts	390	376	360	343	326			
		Amps	1.88	1.81	1.73	1.66	1.58			
	Middle	CFM(L/S)			1251(590)	1206(569)	1148(541)	1080(509)	989(466)	
		RPM			869	910	949	983	1017	
		Watts			436	416	392	368	340	
		Amps			2.11	2.01	1.91	1.8	1.68	
	High	CFM(L/S)				1345(634)	1272(600)	1192(562)	1107(522)	980(462)
		RPM				965	995	1022	1045	1070
		Watts				499	470	441	413	377
		Amps				2.43	2.31	2.18	2.07	1.91
48	Low	CFM(L/S)	1497(706)	1449(683)	1401(661)	1349(636)	1291(609)			
		RPM	676	722	773	816	853			
		Watts	457	448	437	426	413			
		Amps	2.26	2.22	2.18	2.14	2.08			
	Middle	CFM(L/S)			1571(741)	1511(713)	1445(681)	1370(646)	1249(589)	
		RPM			834	872	905	936	972	
		Watts			527	510	493	473	443	
		Amps			2.65	2.59	2.53	2.46	2.35	
	High	CFM(L/S)				1685(795)	1610(759)	1527(720)	1428(673)	1192(562)
		RPM				927	954	980	1003	1041
		Watts				626	604	580	556	510
		Amps				3.22	3.15	3.07	2.98	2.83
60	Low	CFM(L/S)	1865(879)	1822(859)	1770(835)	1712(808)	1643(775)			
		RPM	851	886	919	948	974			
		Watts	641	620	598	578	555			
		Amps	3.08	2.98	2.88	2.79	2.69			
	Middle	CFM(L/S)			1875(884)	1808(853)	1729(816)	1642(774)	1542(727)	
		RPM			961	984	1005	1024	1043	
		Watts			664	639	613	587	558	
		Amps			3.21	3.11	3.0	2.89	2.78	
	High	CFM(L/S)				1905(898)	1826(861)	1736(819)	1615(762)	1479(698)
		RPM				1017	1034	1049	1063	1079
		Watts				703	677	648	619	585
		Amps				3.44	3.34	3.22	3.1	2.97

Table 7-2 Duct Application(230v)

Model Number	Motor Speed	CFM(L/S)(Watts)								
		External Static Pressure-Inches W.C.[kPa]								
		0[0]	0.1[.02]	0.2[.05]	0.3[.07]	0.4[.10]	0.5[.12]	0.6[.15]	0.7[.17]	
24	Low	CFM(L/S)	1005(475)	928(438)	868(410)	797(376)				
		RPM	611	677	729	782				
		Watts	252	250	248	246				
		Amps	1.1	1.09	1.08	1.07				
	Middle	CFM(L/S)				1038(490)	955(451)	846(400)	700(331)	
		RPM				860	895	935	976	
		Watts				374	370	362	354	
		Amps				1.66	1.65	1.63	1.6	
	High	CFM(L/S)						1004(474)	847(400)	604(285)
		RPM						975	1005	1036
		Watts						492	481	468
		Amps						2.26	2.22	2.17
36		CFM(L/S)	1411(666)	1365(645)	1330(628)	1298(613)	1265(597)	1236(584)	1205(569)	1174(554)
		RPM	802	844	886	924	961	997	1037	1075
		Watts	301	316	330	341	350	362	374	386
		Amps	2.29	2.38	2.48	2.56	2.62	2.7	2.79	2.91
48	Low	CFM(L/S)	1694(800)	1614(762)	1545(730)	1473(696)	1398(660)			
		RPM	735	781	820	857	888			
		Watts	521	504	487	471	454			
		Amps	2.33	2.28	2.22	2.17	2.12			
	Middle	CFM(L/S)			1717(811)	1642(775)	1560(737)	1466(692)	1363(644)	
		RPM			874	904	930	957	982	
		Watts			588	566	547	525	502	
		Amps			2.72	2.65	2.59	2.52	2.46	
	High	CFM(L/S)				1822	1722	1625	1515	1394
		RPM				955	977	996	1015	1034
		Watts				691	668	644	618	593
		Amps				3.3	3.23	3.15	3.08	3
60		CFM(L/S)	2001(945)	1954(923)	1907(900)	1860(878)	1814(857)	1768(835)	1724(814)	1681(794)
		RPM	846	885	927	966	1002	1035	1070	1102
		Watts	445	462	486	503	519	534	550	564
		Amps	3.24	3.35	3.5	3.61	3.71	3.8	3.9	3.99

* The above airflow data for reference only.

* In any situation , the airflow of the unit should be in the range of 80% to 130% of 400CFM/Ton.

- The air distribution system has the greatest effect on airflow. The duct system is totally controlled by the contractor. For this reason, the contractor should use only industry-recognized procedures.
- A/C systems require a specified airflow. Each ton of cooling requires between 350 and 450 cubic feet of air per minute (CFM), or 400 CFM nominally.
- Duct design and construction should be carefully done. System performance can be lowered dramatically due to poor duct design.
- Air supply diffusers must be selected and located carefully. They must be sized and positioned to deliver treated air along the perimeter of the space. If they are too small for their intended airflow, they become noisy. If they are not located properly, they cause drafts. Return air grilles must be properly sized to carry air back to the blower. If they are too small, they also cause noise.
- The installers should balance the air distribution system to ensure proper quiet airflow to all rooms in the home. This ensures a comfortable living space.
- An air velocity meter or airflow hood can give a reading of system CFM.
- During installation, installer should select the air speed according to the actual setting static pressure. Please refer to the *Table 7-1 AIRFLOW PERFORMANCE DATA*.

Table 7-3 Refrigerant charge for A/C system

Cooling Mode Mode De Refroidissement		Cooling Charge Chart/Tableau De Charge de Refroidissement													
		Outdoor Ambient Temperature(°F)/Temperature Amdiante Exterieur(en °F)													
		55	60	65	70	75	80	85	90	95	100	105	110	115	
High Pressure Service Port (psig)/Vanne Détectée de Pression Haute(en psig)															
Low Pressure Service Port(psig)	Vanne Détectée de Pression Basse(en psig)	165			303	316	328	350	370	400	426	446	465	487	508
		161			300	313	325	346	366	394	421	440	459	481	503
		157			297	310	322	342	362	389	415	434	453	476	499
		153		282	294	307	319	339	358	384	410	428	446	471	496
		149		279	291	304	316	335	353	374	399	419	443	468	493
		145		275	287	300	312	331	349	370	393	416	440	465	490
		141	256	272	284	297	309	328	346	368	389	413	437	462	486
		137	251	268	280	293	305	324	343	365	386	410	434	459	483
		133	246	264	276	289	301	321	340	361	382	406	430	455	479
		129	241	260	272	285	297	317	336	357	378	403	427	451	475
		125	236	256	268	281	293	313	332	353	374	399	423	447	471
		121	231	252	264	277	289	309	328	349	370	395	420	444	467
		117	226	248	260	273	285	305	324	345	366	392	417	440	463
		113	221	244	256	269	281	301	320	341	362	388	414	437	459
		109	216	240	252	265	277	297	316	337	358	385	411	433	455
105	211	236	248	261	273	293	312	333	354	381	408	429	450		

Table 7-4 Refrigerant charge for A/C system

Cooling Mode Mode De Refroidissement		Cooling Charge Chart/Tableau De Charge de Refroidissement													
		Outdoor Ambient Temperature(°F)/Temperature Amdiante Exterieur(en °F)													
		55	60	65	70	75	80	85	90	95	100	105	110	115	
High Pressure Service Port (psig)/Vanne Détectée de Pression Haute(en psig)															
Low Pressure Service Port(psig)	Vanne Détectée de Pression Basse(en psig)	165			313	328	343	357	370	391	423	448	472	495	521
		161			309	324	339	353	366	387	419	444	468	491	516
		157			305	320	335	349	362	383	415	439	463	486	512
		153		286	301	316	331	345	358	379	411	435	459	482	508
		149		282	297	312	327	341	354	375	407	431	455	478	503
		145		278	293	308	323	337	350	372	404	428	451	474	500
		141	253	274	289	304	319	333	346	368	401	424	447	470	495
		137	246	268	283	298	313	328	342	363	397	421	444	471	501
		133	241	264	279	294	309	324	339	360	394	418	441	463	487
		129	236	260	275	290	305	321	337	358	391	415	438	461	486
		125	231	256	271	286	301	317	333	355	389	412	435	457	482
		121	226	252	267	282	297	313	329	351	386	409	432	454	478
		117	221	248	263	278	293	309	325	348	383	406	429	450	474
		113	216	244	259	274	289	305	321	344	380	403	426	447	470
		109	211	240	255	270	285	301	317	341	377	400	423	443	466
105	206	236	251	266	281	297	313	337	374	397	420	440	462		

Table 7-5 Refrigerant charge for A/C system

48 Cooling Mode Mode De Refroidissement		Cooling Charge Chart/Tableau De Charge de Refroidissement													
		Outdoor Ambient Temperature(°F)/Temperature Amdiante Exterieur(en °F)													
		55	60	65	70	75	80	85	90	95	100	105	110	115	
Low Pressure Service Port(psig) Vanne Détectée de Pression Basse(en psig)		High Pressure Service Port(psig)/Vanne Détecté de Pression Haute(en psig)													
		165			277	298	320	341	359	378	396	421	445	470	494
		161			275	296	318	339	357	376	394	419	443	468	492
		157			273	294	316	337	355	374	392	417	441	466	490
		153		250	271	292	314	335	353	372	390	415	439	464	488
		149		248	269	290	312	333	351	370	388	413	437	462	486
		145		246	267	288	310	331	349	368	386	411	435	460	484
		141	222	244	265	286	308	329	347	366	384	409	433	458	482
		137	220	242	263	284	306	327	345	364	382	407	431	456	480
		133	218	240	261	282	304	325	343	362	380	405	429	454	478
		129	216	238	259	280	302	323	341	360	378	403	427	452	476
		125	214	236	257	278	300	321	339	358	376	401	425	450	474
		121	212	234	255	276	298	319	337	356	374	399	423	448	472
		117	210	232	253	274	296	317	335	354	372	397	421	446	470
		113	208	230	251	272	294	315	333	352	370	395	419	444	468
109	206	228	249	270	292	313	331	350	368	393	417	442	466		
105	204	226	247	268	290	311	329	348	366	391	415	440	464		

Table 7-6 Refrigerant charge for A/C system

60 Cooling Mode Mode De Refroidissement		Cooling Charge Chart/Tableau De Charge de Refroidissement													
		Outdoor Ambient Temperature(°F)/Temperature Amdiante Exterieur(en °F)													
		55	60	65	70	75	80	85	90	95	100	105	110	115	
Low Pressure Service Port(psig) Vanne Détectée de Pression Basse(en psig)		High Pressure Service Port(psig)/Vanne Détecté de Pression Haute(en psig)													
		165			297	318	339	360	379	399	418	442	466	490	514
		161			295	316	337	358	377	397	416	440	464	488	512
		157			293	314	335	356	375	395	414	438	462	486	510
		153		270	291	312	333	354	373	393	412	436	460	484	508
		149		268	289	310	331	352	371	391	410	434	458	482	506
		145		266	287	308	329	350	369	389	408	432	456	480	504
		141	243	264	285	306	327	348	367	387	406	430	454	478	502
		137	241	262	283	304	325	346	365	385	404	428	452	476	500
		133	239	260	281	302	323	344	363	383	402	426	450	474	498
		129	237	258	279	300	321	342	361	381	400	424	448	472	496
		125	235	256	277	298	319	340	359	379	398	422	446	470	494
		121	233	254	275	296	317	338	357	377	396	420	444	468	492
		117	231	252	273	294	315	336	355	375	394	418	442	466	490
		113	229	250	271	292	313	334	353	373	392	416	440	464	488
109	227	248	269	290	311	332	351	371	390	414	438	462	486		
105	225	246	267	288	309	330	349	369	388	412	436	460	484		

8.0 SYSTEM OPERATION

8.1 COMPRESSOR CRANKCASE HEATER(OPTIONAL)

Refrigerant migration during the off cycle can result in a noisy start up. Add a crankcase heater to minimize refrigeration migration, and to help eliminate any start up noise or bearing "wash out".

All heaters are located on the lower half of the compressor shell. Its purpose is to drive refrigerant from the compressor shell during long off cycles, thus preventing damage to the compressor during start-up.

At initial start-up or after extended shutdown periods, make sure the heater is energized for at least 12 hours before the compressor is started. (Disconnect switch on and wall thermostat off.)

The crankcase heater will start up or shut down according to the following logic:

The crankcase heater will start up when the compressor is off and $T_4 < 41^\circ\text{F}$.

The crankcase heater will shut down when $T_4 \geq 45^\circ\text{F}$

In any condition, the crankcase heater will shut down when the compressor is on

8.2 PROTECTION

Discharge temperature protection:

If discharge temp. is $> 275^\circ\text{F}$, the compressor will shut down, If discharge temp. is $< 194^\circ\text{F}$, the compressor will resume operation.

High pressure protection

If high pressure is $> 638\text{PSIG}$, the compressor and the outdoor fan motor will stop running.

If high pressure is $< 464\text{PSIG}$, the compressor and the outdoor fan motor will resume running(3 minutes delay necessary).

Low pressure protection

When low pressure is $< 21\text{PSIG}$, the compressor and the outdoor fan motor will stop running.

When low pressure is $> 44\text{PSIG}$, the compressor and the outdoor fan motor will resume running(3 minutes delay necessary).

In stand-by status, if low pressure protection was detected, the compressor will not start.

If protection cycles occur four times within 30 minutes, the compressor and outdoor fan will shut down. In this condition, the system needs to power on once more in order to keep on working.

8.3 THERMOSTAT SIGNALS

Table 8-1: Thermostat Signals

Signal	State	Board Function
G	ON	Blower instant ON
	OFF	Blower 90 sec. delay OFF
G & W1	ON	Blower instant ON Heater bank 1 elec.onstant ON
	OFF	Heater bank 1 elec.instant OFF Blower 90 sec. delay OFF
G & W1& W2	ON	Blower instant ON Heater 1 instant ON Heater 2 instant ON
	OFF	Blower 90 sec. delay OFF Heater 1 instant OFF Heater 2 instant OFF
G & Y	ON	Blower instant ON Compressor and outdoor fan instant ON
	OFF	Compressor and outdoor fan instant OFF Blower fan delay 90 sec. OFF
G & Y & W1	ON	Blower instant ON Compressor and outdoor fan instant ON Heater 1 instant ON
	OFF	Blower fan delay 90 sec. OFF Compressor and outdoor fan instant OFF Heater 1 instant OFF
G & Y & W1 & W2	ON	Blower instant ON Compressor and outdoor fan instant ON Heater 1 instant ON Heater 2 instant ON
	OFF	Blower fan delay 90 sec. OFF Compressor and outdoor fan instant OFF Heater 1 instant OFF Heater 2 instant OFF

Table 8-2: Thermostat Wire Color

Thermostat Wire Color	Function
Red	Power wire
Black	Power wire
White	Heater signal 1
Green	Blower fan signal
Yellow	Compressor signal
Blue	Reversing valve signal
White/Black	Heater signal 2

9.0 OPERATION CHECK-UP

- **Cooling Startup**

1. Turn thermostat to OFF and turn power to ON
2. Turn ON thermostat and set as high as possible
3. Turn Fan switch ON and indoor blower should run
4. Turn fan switch to AUTO, system switch to COOL and thermostat temperature setting below room temperature.
Unit should run in COOLING mode.

After unit has run for a while, check the following:

1. Are fans running properly?
2. Is compressor running correctly?
3. Check refrigerant charge.
4. Check duct connection for leaks.
5. Check for tubing and sheet metal rattles.

(See Wiring Diagram for electric connection detail.)

10.0 TROUBLE SHOOTING



WARNING

Component trouble shooting requires opening control box with power on. Use extreme care while working on this condition. Check nameplate and this instruction when making wire connections.

AC System Wiring Diagram (24/48):

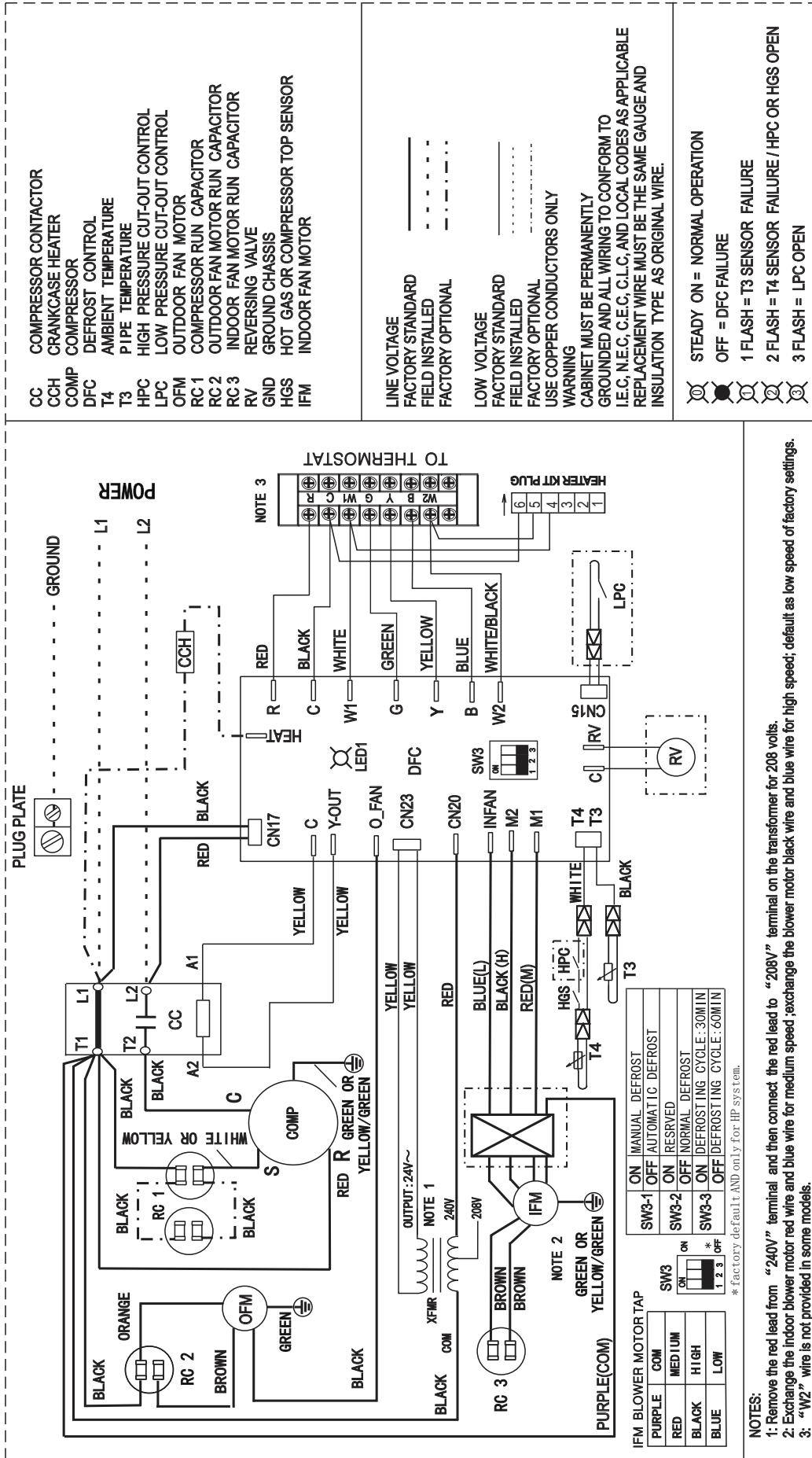

AC System Wiring Diagram (36/60):

