

Product Exploded View

Model: YMSFXH(C) 018BAAK—X
Power source: 208/230v 1Ph 60Hz
Code: 220M070201520

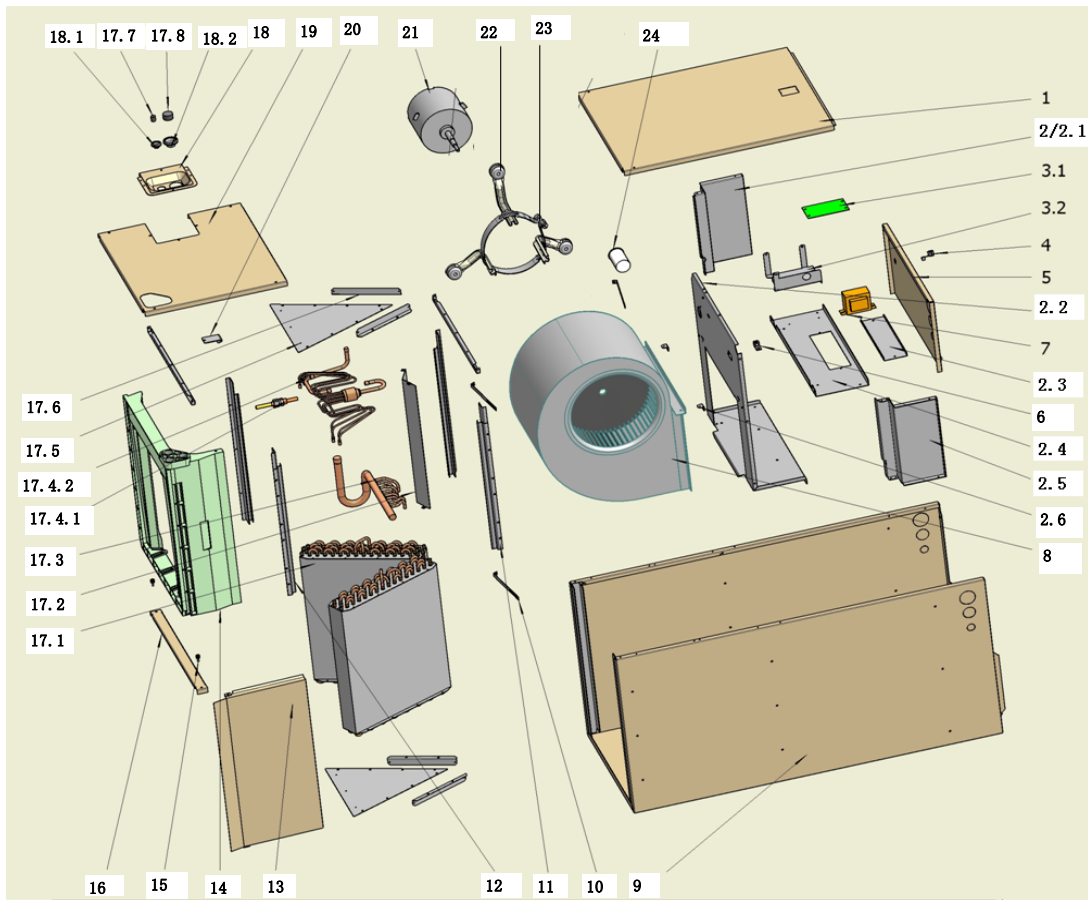

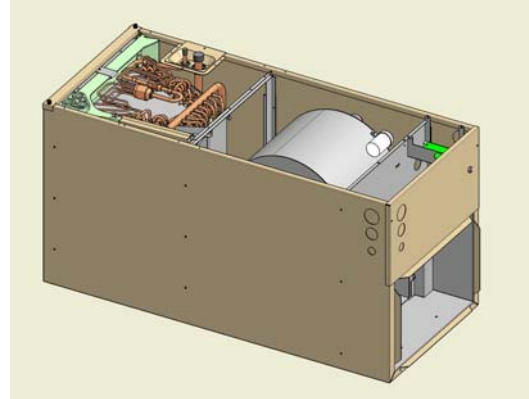
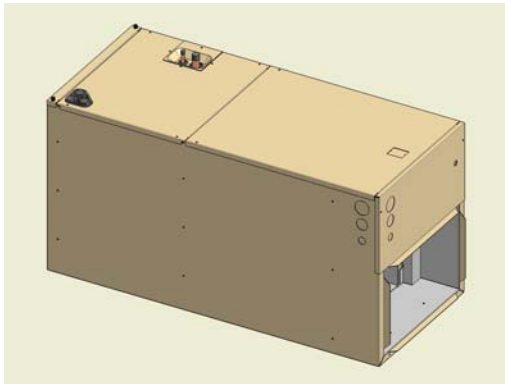
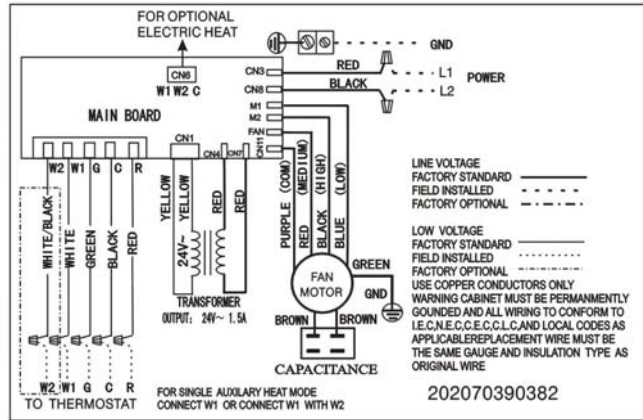
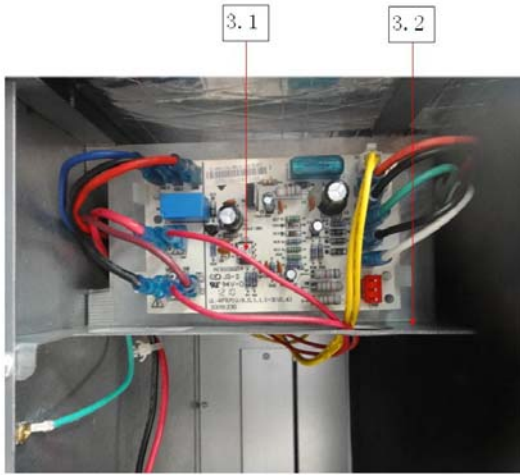

Product Exploded View Schedule

No.	BOM code	Part Name	Quantity	Price(\$\$)	Remark
1	201M270390208	Upside board ass'y	1		
2	201M270390241	Air duct assy'	1		
2.1	201M270390201	Side board I	1		
2.2	201M270390206	Fixing board	1		
2.3	201M270390203	Clapboard	1		
2.4	201M270390205	Baffle ass'y	1		
2.5	201M270390200	Side board II	1		
2.6	201M270890239	Fixing board of fan	2		
3	203M370390041	E-part box ass'y	1		
3.1	201M396090006	Main control board ass'y	1		
3.2	201M270390213	Electric installation board	1		
4	201M102000301	Clamp	1		
5	201M270390195	Side board ass'y	1		
6	202M301440007	Grounding terminal	1		
7	202M300900130	24V AC transformer	1		
8	201M200300834	Fan ass'y	1		
9	201M270390210	Base ass'y	1		
10	201M270390363	2 water tray brace	2		
11	201M270390197	Drainage pan supporting board	1		
12	201M270390198	Drainage pan supporting board	1		
13	201M270390204	Drainage pan	1		
14	201M170390011	Drainage pan	1		
15	202M500300039	Screw	2		
16	201M270390196	Cover board	1		
17	201M570290049	Evaporator ass'y	1		
17.1	201M570290050	Evaporator	2		
17.2	201M270390234	Evaporator joint board	1		
17.3	201M670290110	Outlet pipe ass'y	1		
17.4	201M670290109	Inlet pipe ass'y	1		
17.4.1	201M600801447	Throttling valve	1		
17.4.2	201M600500223	Distributor	1		
17.5	201M270590077	Evaporator baffle	2		
17.6	201M270390212	Waterproof board	4		
17.7	202M700300015	Rubber plug	1		
17.8	202M700300014	Rubber plug	1		
18	201M270390192	Cover plate ass'y	1		
18.1	202M770390004	Rubber ring	1		
18.2	202M770390005	Rubber ring	1		
19	201M270390207	Underside board ass'y	1		
20	201M270390194	Drainage pan clap	1		
21	202M400400276	Motor	1		
22	201M270390288	Motor bracket I	3		
23	201M270390273	Motor bracket II	1		
24	202M401100409	Motor capacitor	1		

Product Exploded View



Model: YMSFXH(C) 024BAAK—X
Power source: 208/230v 1Ph 60Hz
Code: 220M070301200

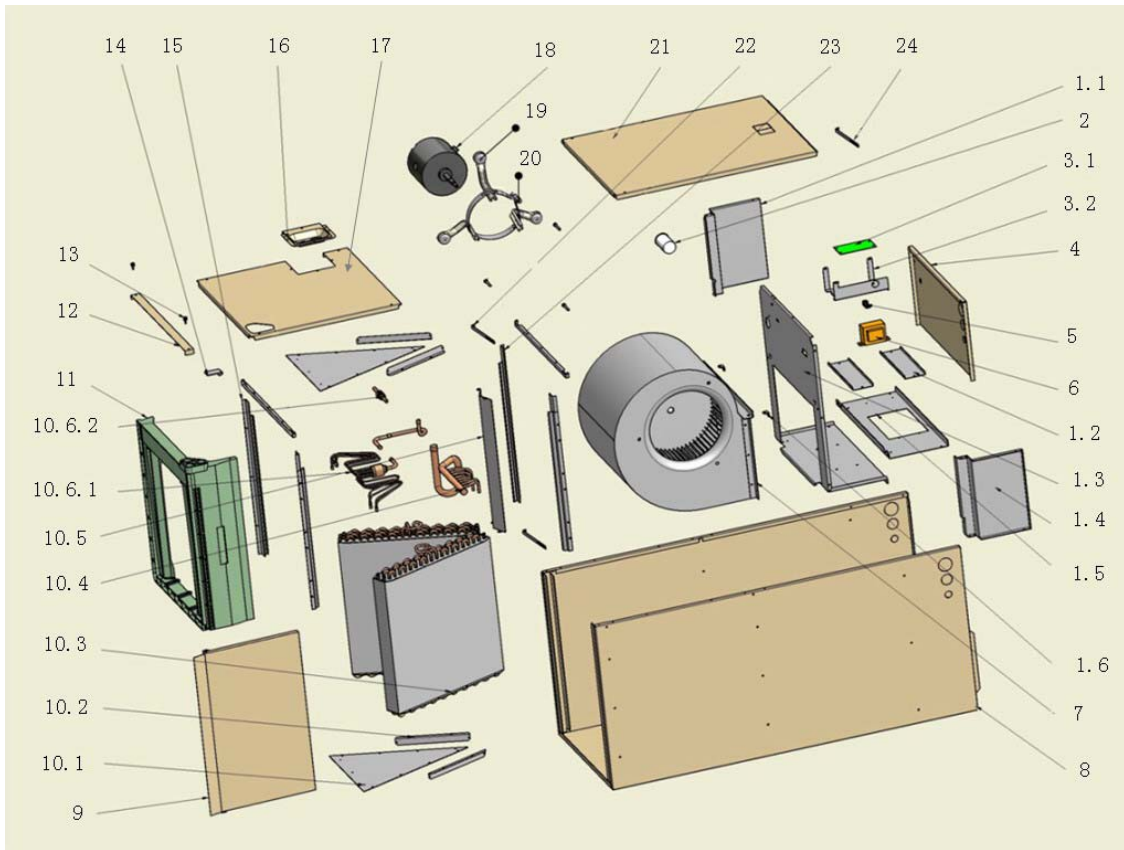
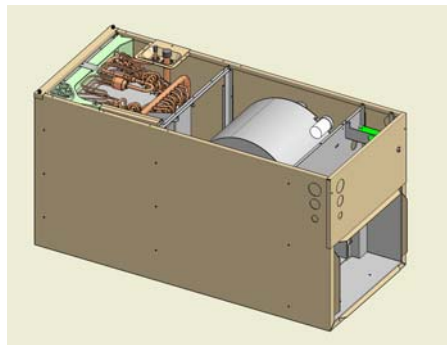
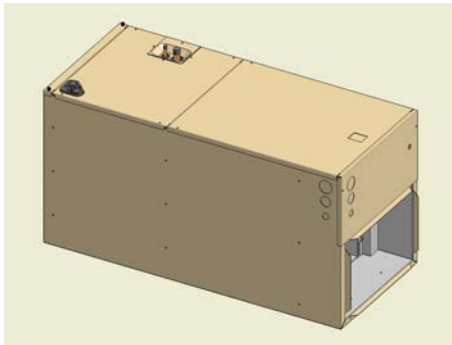

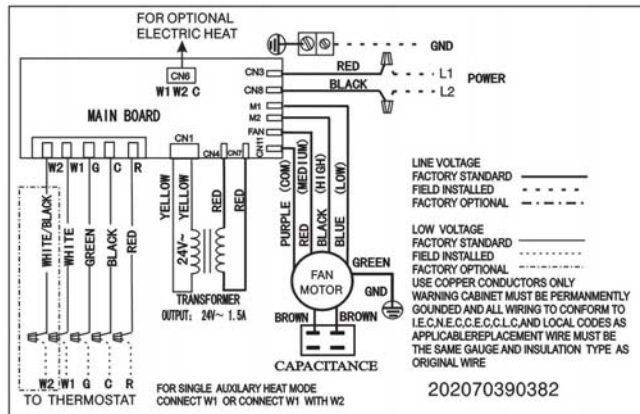
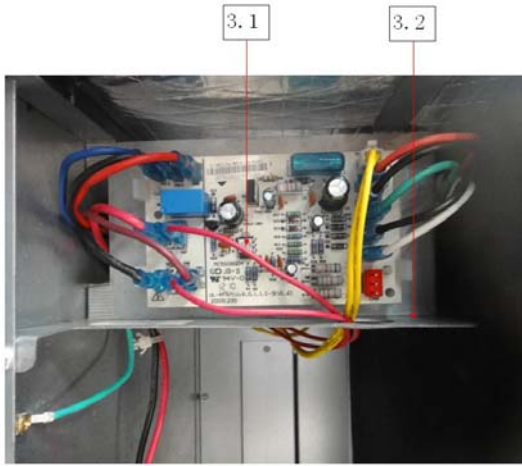

Product Exploded View Schedule

No.	BOM code	Part Name	Quantity	Price(\$\$)	Remark
1	201M270390241	Air duct ass'y	1		
1.1	201M270390201	Side board I	1		
1.2	201M270390203	Clapboard	1		
1.3	201M270390206	Fixing board	1		
1.4	201M270390200	Side board II	1		
1.5	201M270390205	Baffle ass'y	1		
1.6	201M270890239	Fixing board of fan	2		
2	202M401100409	Motor capacitor	1		
3	203M370390041	E-part box ass'y	1		
3.1	201M396090006	Main control board ass'y	1		
3.2	201M270390213	Electric installation board	1		
4	201M270390195	Side board ass'y	1		
5	202M301440007	Grounding terminal	1		
6	202M300900130	24V AC transformer	1		
7	201M200300834	Fan ass'y	1		
8	201M270390210	Base ass'y	1		
9	201M270390204	Drainage pan	1		
10	201M570390031	Evaporator ass'y	1		
10.1	201M270590077	Evaporator baffle	2		
10.2	201M270390212	Waterproof board	4		
10.3	201M570390026	Evaporator	2		
10.4	201M670390106	Output pipe ass'y	1		
10.5	201M270390234	Evaporator joint board	1		
10.6	201M670390094	Input pipe ass'y	1		
10.6.1	201M600500030	Distributor	1		
10.6.2	201M600800870	Throttle	1		
11	201M170390011	Drainage pan	1		
12	201M270390196	Cover board	1		
13	202M500300039	Screw	2		
14	201M270390194	Drainage pan clap	1		
15	201M270390198	Drainage pan supporting board	1		
16	201M270390192	Cover plate ass'y	1		
17	201M270390207	Underside board ass'y	1		
18	202M400400277	Motor	1		
19	201M270390288	Motor bracket I	3		
20	201M270390273	Motor bracket II	1		
21	201M270390208	Upside board ass'y	1		
22	201M270390202	Drainage pan clamp	1		
23	201M270390197	Drainage pan supporting board	1		
24	201M270390363	2 water tray brace	2		

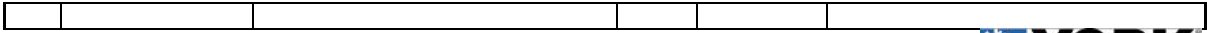

Product Exploded View



Model: YMSFXH(C) 036BAAK--X
Power source: 208/230v 1Ph 60Hz
Code: 220M070502460

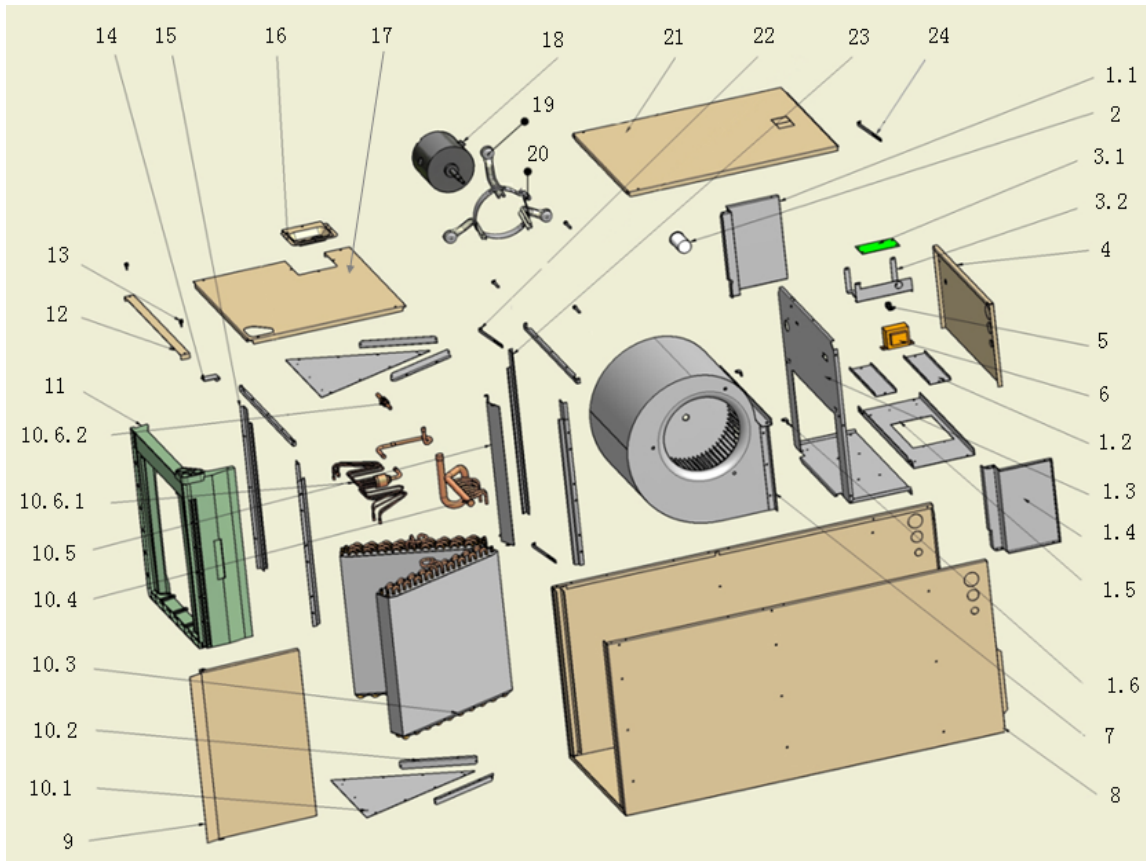
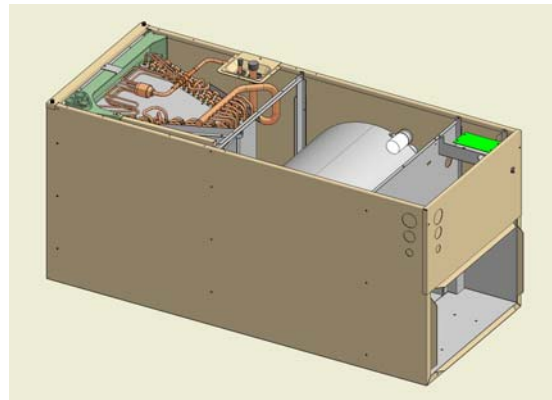
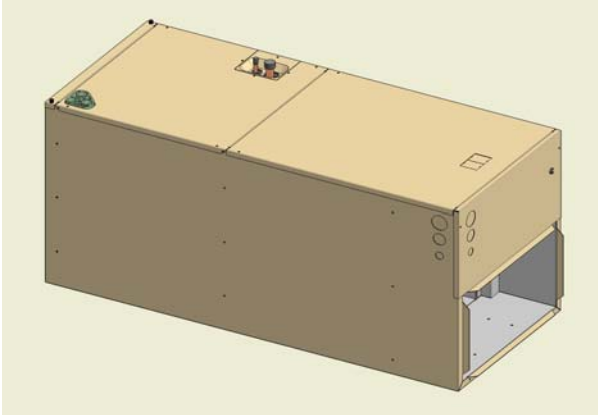

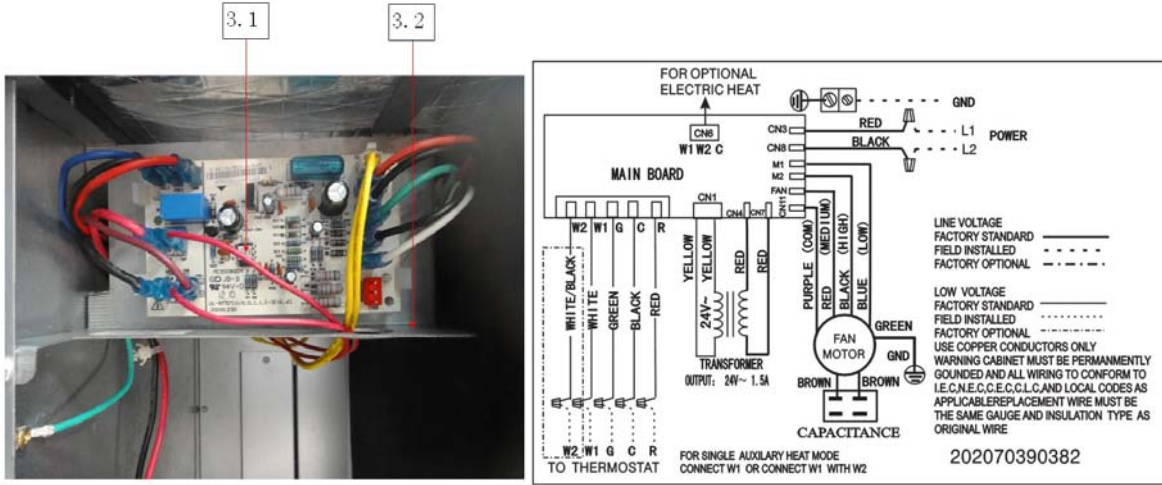

Product Exploded View Schedule

No.	BOM code	Part Name	Quantity	Price(\$\$)	Remark
1	201M270590123	Air duct ass'y	1		
1.1	201M270590085	Side board I	1		
1.2	201M270390203	Clapboard	2		
1.3	201M270590090	Fixing board	1		
1.4	201M270590084	Side board II	1		
1.5	201M270590089	Baffle ass'y	1		
1.6	201M270890239	Fixing board of fan	2		
2	202M401000058	Compressor capacitor	1		
3	203M370590052	E-part box ass'y	1		
3.1	201M396090006	Main control board ass'y	1		
3.2	201M270590096	Electric installation board	1		
4	201M270590079	Side board ass'y	1		
5	202M301440007	Grounding terminal	1		
6	202M300900130	24V AC transformer	1		
7	201M200300276	Fan ass'y	1		
8	201M270590088	Base ass'y	1		
9	201M270590091	Drainage pan	1		
10	201M570590098	Evaporator ass'y	1		
10.1	201M270590094	Evaporator baffle	2		
10.2	201M270590093	Waterproof board	4		
10.3	201M570590044	Evaporator	2		
10.4	201M670590229	Outlet tube components	1		
10.5	201M270590115	Evaporator joint board ass'y	1		
10.6	201M670590228	Inlet pipe ass'y	1		
10.6.1	201M670590104	Input pipe	1		
10.6.2	201M600800295	Throttle	1		
11	201M170590002	Drainage pan	1		
12	201M270590080	Cover board	1		
13	202M500300039	Screw	2		
14	201M270390194	Drainage pan clap	1		
15	201M270590081	Drainage pan supporting board	1		
16	201M270390192	Cover plate ass'y	1		
17	201M270590086	Underside board ass'y	1		
18	202M400400279	Motor	1		
19	201M270390288	Motor bracket I	3		
20	201M270390273	Motor bracket II	1		
21	201M270590087	Upside board ass'y	1		
22	201M270390363	2 water tray brace	2		
23	201M270590082	Drainage pan supporting board	1		
24	201M270390202	Drainage pan clamp	1		

Product Exploded View



Model: YMSFXH(C) 048BAAK—X
Power source: 208/230v 1Ph 60Hz
Code: 220M070702240

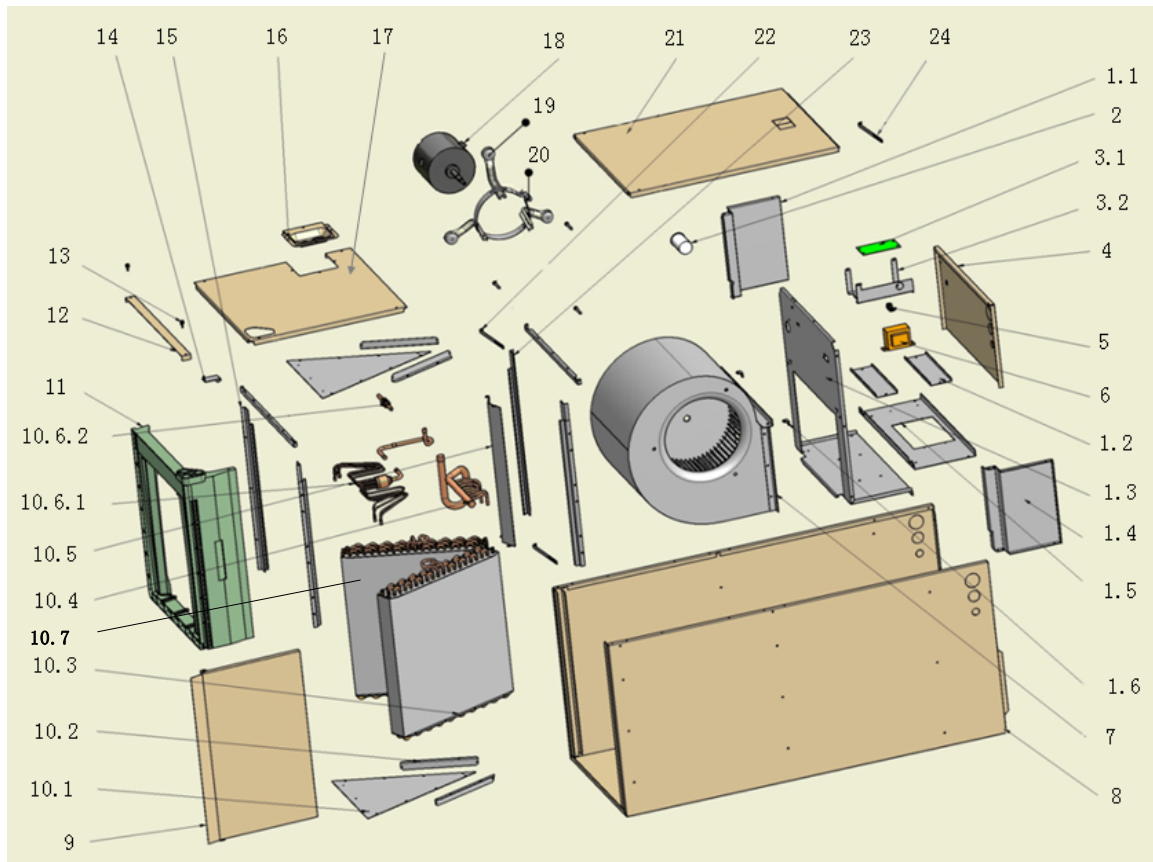
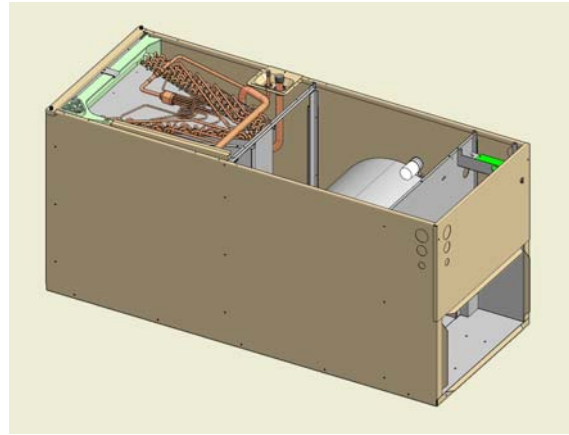
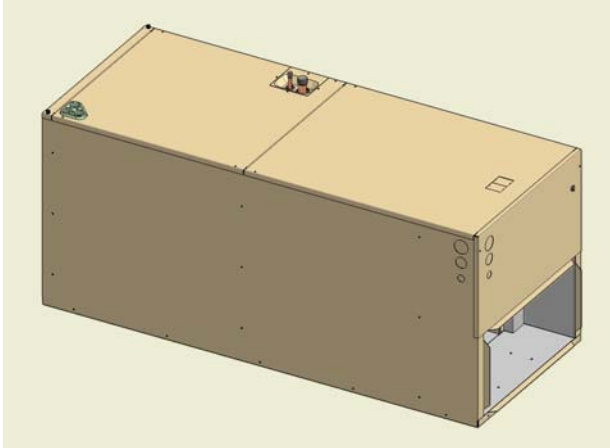

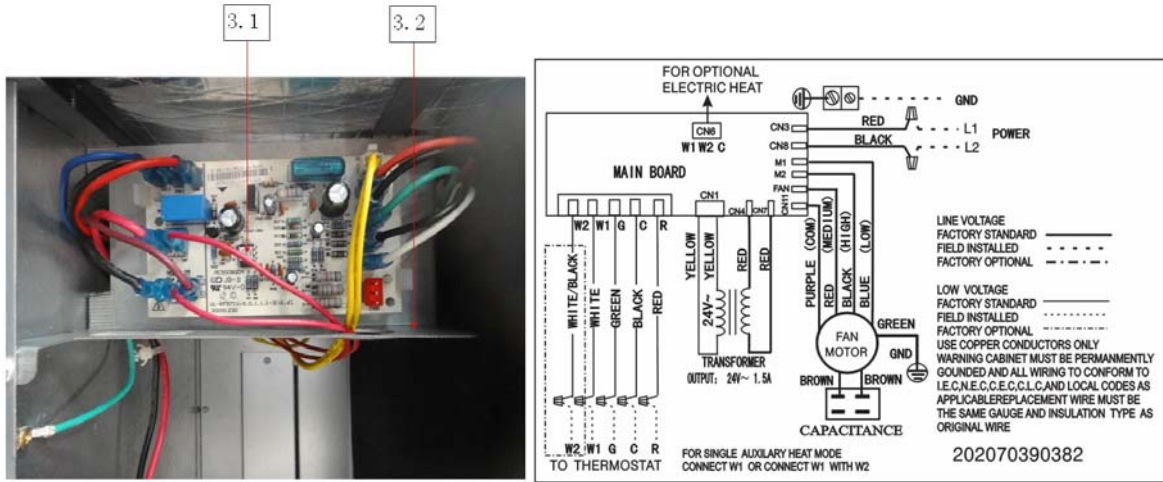

Product Exploded View Schedule

No.	BOM code	Part Name	Quantity	Price(\$\$)	Remark
1	201M270890101	Air duct assy'	1		
1.1	201M270890073	Side board I	1		
1.2	201M270390203	Clapboard	2		
1.3	201M270890071	Fixing board	1		
1.4	201M270890072	Side board II	1		
1.5	201M270890070	Baffle	1		
1.6	201M270890239	Fixing board of fan	2		
2	202M401000303	Compressor capacitor	1		
3	203M370590052	E-part box ass'y	1		
3.1	201M396090006	Main control board ass'y	1		
3.2	201M270590096	Electric installation board	1		
4	201M270890064	Side board ass'y	1		
5	202M301440007	Grounding terminal	1		
6	202M300900130	24V AC transformer	1		
7	201M200300276	Fan ass'y	1		
8	201M270890076	Base ass'y	1		
9	201M270890068	Drainage pan	1		
10	201M570790103	Evaporator ass'y	1		
10.1	201M270890081	Evaporator baffle	2		
10.2	201M270890079	Waterproof board	4		
10.3	201M570790105	Evaporator I	1		
10.4	201M670790241	Outlet pipe ass'y	1		
10.5	201M270890094	Evaporator joint board ass'y	1		
10.6	201M670790234	Inlet pipe ass'y	1		
10.6.1	201M670890132	Input pipe	1		
10.6.2	201M600801171	Throttle	1		
10.7	201M570790104	Evaporator II	1		
11	201M170890002	Drainage pan	1		
12	201M270890065	Cover board	1		
13	202M500300039	Screw	2		
14	201M270390194	Drainage pan clap	1		
15	201M270890067	Drainage pan supporting board	1		
16	201M270390192	Cover plate ass'y	1		
17	201M270890074	Underside board ass'y	1		
18	202M400400281	Motor	1		
19	201M270390288	Motor bracket I	3		
20	201M270390273	Motor bracket II	1		
21	201M270890075	Upside board ass'y	1		
22	201M270390363	2 water tray brace	2		
23	201M270890066	Drainage pan supporting board	1		
24	201M270390202	Drainage pan clamp	1		

Product Exploded View



Model: YMSFXH(C) 060BAAK—X
Power source: 208/230v 1Ph 60Hz
Code: 220M070801031

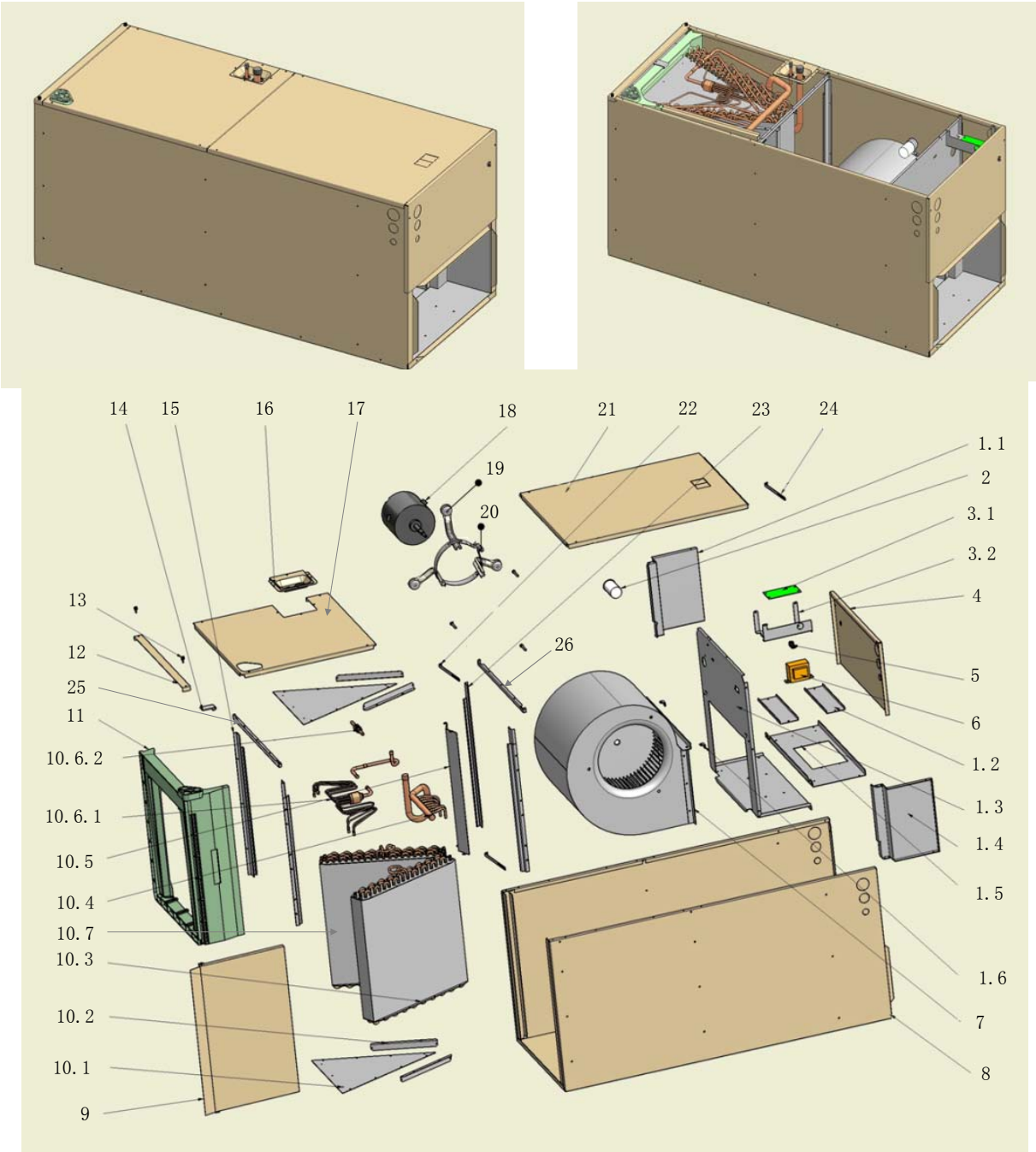

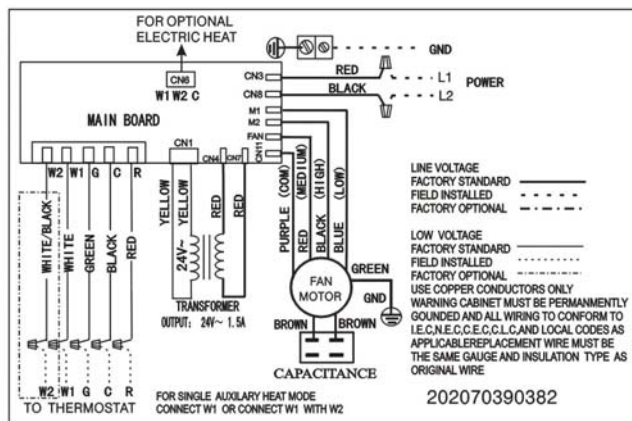
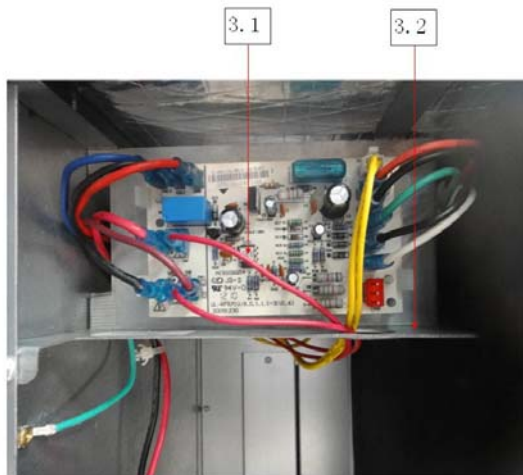

Product Exploded View Schedule

No.	BOM code	Part Name	Quantity	Price(\$\$)	Remark
1	201M270890101	Air duct ass'y	1		
1.1	201M270890073	Side board I	1		
1.2	201M270390203	Clapboard	2		
1.3	201M270890071	Fixing board	1		
1.4	201M270890072	Side board II	1		
1.5	201M270890070	Baffle	1		
1.6	201M270890239	Fixing board of fan	2		
2	202M401000303	Capacitor	1		
3	203M370590052	E-part box ass'y	1		
3.1	201M396090006	Main control board ass'y	1		
3.2	201M270590096	Electric installation board	1		
4	201M270890064	Side board ass'y	1		
5	202M301440007	Grounding terminal	1		
6	202M300900130	24V AC transformer	1		
7	201M200300276	Fan ass'y	1		
8	201M270890076	Base ass'y	1		
9	201M270890068	Drainage pan	1		
10	201M570890062	Evaporator ass'y	1		
10.1	201M270890081	Evaporator baffle	2		
10.2	201M270890079	Waterproof board	4		
10.3	201M570890059	Evaporator ass'y	1		
10.4	201M670890288	Output tube components	1		
10.5	201M270890094	Evaporator joint board ass'y	1		
10.6	201M6708A0041	Input tube components	1		
10.6.1	201M600800285	Throttle	1		
10.6.2	201M600500118	Distributor	1		
10.7	201M570890058	Evaporator ass'y	1		
11	201M170890002	Drainage pan	1		
12	201M270890065	Cover board	1		
13	202M500300039	Screw	2		
14	201M270390194	Drainage pan clap	1		
15	201M270890067	Drainage pan supporting board	1		
16	201M270390192	Cover plate ass'y	1		
17	201M270890074	Underside board ass'y	1		
18	202M400400282	Motor	1		
19	201M270390288	Motor bracket I	3		
20	201M270390273	Motor bracket II	1		
21	201M270890075	Upside board ass'y	1		
22	201M270390363	2 water tray brace	2		
23	201M270890066	Drainage pan supporting board	1		
24	201M270390202	Drainage pan clamp	1		
25	201M270890069	Supporting bar	1		
26	201M270890107	Supporter ass'y	1		