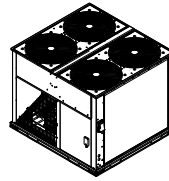


# INSTALLATION MANUAL

**R-410A**

**MODELS: YC090 Thru 300  
YD120 Thru 240**

**7.5 - 25 Ton  
60 Hertz**



## TABLE OF CONTENTS

Nomenclature . . . . .	2	Phasing . . . . .	8
General . . . . .	2	Electrical Data . . . . .	9
Renewal Parts . . . . .	3	Refrigerant Mains . . . . .	11
Agency Approvals . . . . .	3	Piping And Electrical Connections . . . . .	21
Inspection . . . . .	3	Start-Up . . . . .	21
Physical Data . . . . .	4	Crankcase Heater . . . . .	21
Installation . . . . .	5	Operation . . . . .	22
Preceding Installation . . . . .	5	Sequence of Operation . . . . .	22
Limitations . . . . .	5	Cooling Sequence Of Operation . . . . .	22
Location . . . . .	5	Unit Control Board Option Setup . . . . .	25
Clearances . . . . .	7	Troubleshooting . . . . .	26
Rigging . . . . .	7	Typical Wiring Diagrams . . . . .	34

## LIST OF TABLES

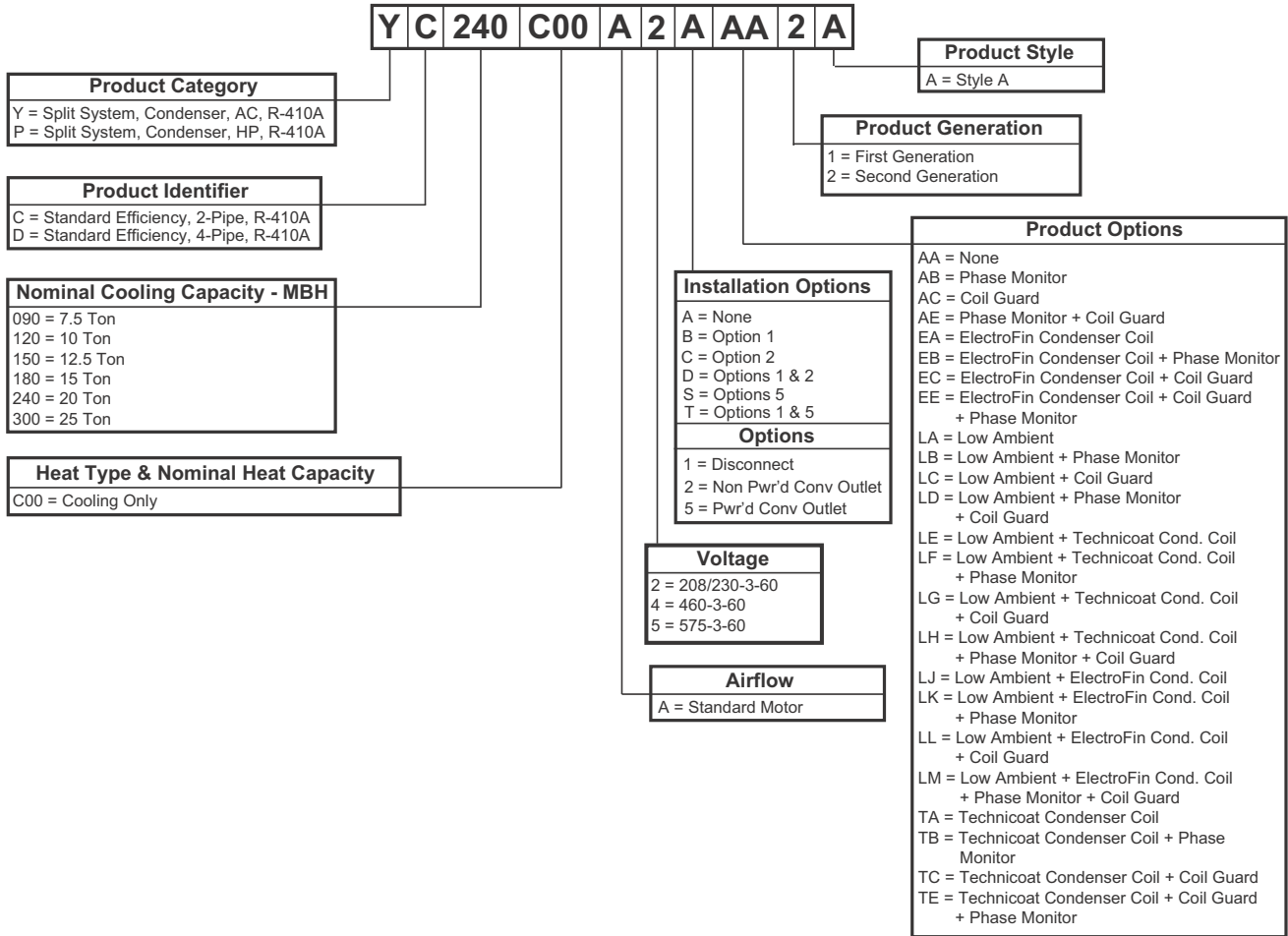
1 YC090 - 300 and YD120 - 240 Physical Data . . . . .	4	7 YC090, YC/YD120, YC/YD150 Unit Height Dimensions . . . . .	19
2 Unit Application Data . . . . .	5	8 YC/YD180, YC/YD240 and YC300 Unit Height Dimensions . . . . .	21
3 Corner Weights & Center of Gravity . . . . .	6	9 Piping And Electrical Connection Sizes (Inches) . . . . .	21
4 Minimum Clearances . . . . .	7	10 YC090 thru 300 Unit Control Board Flash Codes . . . . .	24
5 Electrical Data - Outdoor Unit - AC Without Powered Convenience Outlet . . . . .	9	11 YD120 thru 240 Unit Control Board Flash Codes . . . . .	24
6 Electrical Data - Outdoor Unit - AC With Powered Convenience Outlet . . . . .	10		

## LIST OF FIGURES

1 Corner Weights & Center Of Gravity . . . . .	6	15 YC090 Charging Chart . . . . .	29
2 Typical Rigging . . . . .	7	16 YC120 Charging Chart . . . . .	29
3 Typical Field Wiring Diagram - NC090 Evaporator Unit with YC090 Condenser Unit . . . . .	13	17 YD120 Charging Chart . . . . .	30
4 Typical Field Wiring Diagram - NC120 thru 240 Evaporator Unit with YC120 thru 240 Condenser Unit . . . . .	14	18 YC150 Charging Chart . . . . .	30
5 NC120 - 240 Liquid Line Solenoid Wiring . . . . .	14	19 YD150 Charging Chart . . . . .	31
6 Typical Field Wiring Diagram - ND120 thru 240 Air Handling Unit with YD120 thru 240 Condensing Unit . . . . .	15	20 YC180 Charging Chart . . . . .	31
7 Typical Field Wiring Diagram - Twin NC120 thru 240 Evaporator Units with 4-Pipe Condenser Unit . . . . .	16	21 YD180 Charging Chart . . . . .	32
8 NC120 - 240 Liquid Line Solenoid Wiring . . . . .	16	22 YC240 Charging Chart . . . . .	32
9 Typical Field Wiring Diagram - Single 4-Pipe Evaporator Unit with Twin Condenser Units . . . . .	17	23 YD240 Charging Chart . . . . .	33
10 Typical Field Wiring Diagram - Twin NC090 Evaporator Units with YD180 Condenser Unit . . . . .	18	24 YC300 Charging Chart . . . . .	33
11 YC090, YC/YD120, YC/YD150 Unit Dimensions . . . . .	19	25 Typical YC090 Condensing Unit Wiring Diagram . . . . .	34
12 YC/YD180, YC/YD240 & YC300 Unit Dimensions and Piping & Electrical Dimensions . . . . .	20	26 Typical YC120 - 150 Condensing Unit Wiring Diagram . . . . .	35
13 Fan Orientation - Control Box End . . . . .	24	27 Typical YD120 - 150 Condensing Unit Wiring Diagram . . . . .	36
14 Unit Control Board . . . . .	25	28 Typical YC180 Condensing Unit Wiring Diagram . . . . .	37
		29 Typical YD180 - 240 Condensing Unit Wiring Diagram . . . . .	38
		30 Typical YC240 Condensing Unit Wiring Diagram . . . . .	39
		31 Typical YC300 Condensing Unit Wiring Diagram . . . . .	40

## Nomenclature

### Configured Split Condenser Model Number Nomenclature



## General

These condensing units are designed for outdoor installation on a roof or at ground level. Every unit is completely piped and wired at the factory and is shipped ready for immediate installation. Only the liquid and suction lines to the evaporator coil, the filter drier, the thermostat wiring and the main power wiring are required to complete the installation. Each unit is dehydrated, evacuated, leak tested and pressure tested at 450 psig before being pressurized with a holding charge of refrigerant R-410A for shipment and/or storage.

All controls are located in the front of the unit and are readily accessible for maintenance, adjustment and service. All wiring (power and control) can be made through the front of the unit.

### ⚠ CAUTION

This Split-System (Air Condensing / Heat Pump / Air Handling) unit is one component of an entire system. As such it requires specific application considerations with regard to the rest of the system (air handling unit, duct design, condensing unit, refrigerant piping and control scheme).

Failure to properly apply this equipment with the rest of the system may result in premature failure and/or reduced performance / increased costs. Warranty coverage specifically excludes failures due to improper application and Unitary Products specifically disclaims any liability resulting from improper application.

Please refer to the equipment Technical Guide, Installation Manual and the piping applications bulletin 247077 or call the applications department for Unitary Products @ 1-877-UPG-SERV for guidance.

## Safety Considerations

Installer should pay particular attention to the words: *NOTE*, *CAUTION*, and *WARNING*. *Notes* are intended to clarify or make the installation easier. *Cautions* are given to prevent equipment damage. *Warnings* are given to alert installer that personal injury and/or equipment damage may result if installation procedure is not handled properly.

### **WARNING**

Improper installation may create a condition where the operation of the product could cause personal injury or property damage. Improper installation, adjustment, alteration, service or maintenance can cause injury or property damage. Refer to this manual for assistance or for additional information, consult a qualified contractor, installer or service agency.

### **WARNING**

Before performing service or maintenance operations on unit, turn off main power switch to unit. Electrical shock could cause personal injury. Improper installation, adjustment, alteration, service or maintenance can cause injury or property damage. Refer to this manual. For assistance or additional information consult a qualified installer, service agency or the gas supplier.

### **CAUTION**

This system uses R-410A Refrigerant which operates at higher pressures than R-22. No other refrigerant may be used in this system. Gage sets, hoses, refrigerant containers and recovery systems must be designed to handle R-410A. If you are unsure, consult the equipment manufacturer. Failure to use R-410A compatible servicing equipment may result in property damage or injury.

### **CAUTION**

This product must be installed in strict compliance with the enclosed installation instructions and any applicable local, state and national codes including, but not limited to, building, electrical, and mechanical codes.

## Reference

This instruction covers the installation and operation of the basic condensing unit. For refrigerant piping installation instructions refer to document 247077 "Application Data - General Piping Recommendations for Split System Air Conditioning and Heat Pumps". For information on the installation and operation of the evaporator blower units, refer to Instruction Manual No. 508526.

All accessories come with a separate Installation Manual.

## Renewal Parts

Contact your local Source 1 Distribution Center for authorized replacement parts.

## Agency Approvals

Design certified by CSA as follows:

1. For use as a cooling unit.
2. For outdoor installation only.

## Inspection

As soon as a unit is received, it should be inspected for possible damage during transit. If damage is evident, the extent of the damage should be noted on the carrier's freight bill. A separate request for inspection by the carrier's agent should be made in writing.

## Physical Data

**Table 1: YC090 - 300 and YD120 - 240 Physical Data**

Component	Models										
	YC090	YC120	YD120	YC150	YD150	YC180	YD180	YC240	YD240	YC300	
<b>Nominal Tonnage</b>	<b>7.5</b>	<b>10</b>	<b>10</b>	<b>12.5</b>	<b>12.5</b>	<b>15</b>	<b>15</b>	<b>20</b>	<b>20</b>	<b>25</b>	
<b>REFRIGERANT</b>											
Refrigerant type	R-410A	R-410A	R-410A	R-410A	R-410A	R-410A	R-410A	R-410A	R-410A	R-410A	
Holding charge (lb) <sup>1</sup>	1.0	1.0	1.0	1.0	1.0	1.0	1.0	1.0	1.0	1.0	
Operating Charge (lb) <sup>2</sup>	System #1	14.0	18.0	9.9	24.0	11.5	27.0	13.5	33.5	18.8	35
	System #2	---	---	9.9	---	11.5	---	13.5	---	18.8	---
<b>DIMENSIONS (inches)</b>											
Length	59.1	59.1	59.1	59.1	59.1	59.1	59.1	59.1	59.1	59.1	
Width	31.9	31.9	31.9	31.9	31.9	64.1	64.1	64.1	64.1	64.1	
Height	44.5	50.0	50.0	50.0	50.0	44.5	44.5	50.0	50.0	50.0	
<b>WEIGHTS (lb)</b>											
Shipping	390	499	493	499	493	914	899	945	930	945	
Operating	387	497	490	497	490	909	894	942	927	942	
<b>COMPRESSORS<sup>3</sup></b>											
Type	Single Scroll	Tandem Scroll	Single Scroll	Tandem Scroll	Single Scroll	Tandem Scroll	Single Scroll	Tandem Scroll	Single Scroll	Tandem Scroll	
Quantity	1	1	2	1	2	1	2	1	2	1	
Nominal Capacity (Tons)	System #1	7.5	10	5	12.5	6.3	15	7.5	20	10	25
	System #2	---	---	5	---	6.3	---	7.5	---	10	---
Capacity Stages	System #1	1	2	1	2	1	2	1	2	1	2
	System #2	---	---	1	---	1	---	1	---	1	---
<b>SYSTEM DATA</b>											
No. Refrigeration Circuits	1	1	2	1	2	1	2	1	2	1	
Suction Line OD (in.)	1 1/8	1 3/8	1 1/8	1 3/8	1 1/8	1 5/8	1 3/8	1 5/8	1 3/8	1 5/8	
Liquid Line OD (in.)	5/8	7/8	5/8	7/8	5/8	7/8	5/8	7/8	5/8	7/8	
<b>OUTDOOR COIL DATA</b>											
Face area (Sq. Ft.)	23.8	29.0	29.0	29.0	29.0	47.5	47.5	58.1	58.1	58.1	
Rows	1	1	1	1	1	1	1	1	1	1	
Fins per inch	23	23	23	23	23	23	23	23	23	23	
Tube diameter (in./MM)	0.71 / 18	0.71 / 18	0.71 / 18	0.71 / 18	0.71 / 18	0.71 / 18	0.71 / 18	0.71 / 18	0.71 / 18	0.71 / 18	
Circuitry Type	2-pass	2-pass	2-pass	2-pass	2-pass	2-pass	2-pass	2-pass	2-pass	2-pass	
Refrigerant Control	---	---	---	---	---	---	---	---	---	---	
<b>CONDENSER FAN DATA</b>											
No. Fans / Diameter (in.)	2/24	2/24	2/24	2/24	2/24	4/24	4/24	4/24	4/24	4/24	
Type	Axial	Axial	Axial	Axial	Axial	Axial	Axial	Axial	Axial	Axial	
Drive type	Direct	Direct	Direct	Direct	Direct	Direct	Direct	Direct	Direct	Direct	
No. speeds	1	1	1	1	1	1	1	1	1	1	
Number of motors	System #1	2	2	2	2	4	2	4	2	4	
	System #2	---	---	---	---	---	2	---	2	---	
Motor HP (ea.)	1/3	3/4	3/4	3/4	3/4	1/3	1/3	3/4	3/4	3/4	
Rotation <sup>4</sup>	CW	CW	CW	CW	CW	CW	CW	CW	CW	CW	
RPM	850	1100	1100	1100	1100	850	850	1100	1100	1100	
Nominal CFM	System #1	7500	9800	9800	9800	9800	15000	7500	19600	9800	19600
	System #2	---	---	---	---	---	7500	---	9800	---	

1. Holding Charge is the amount in the unit as shipped from the factory.
2. Includes matched indoor blower unit with 25 ft of piping.
3. All compressors include crankcase heaters.
4. When viewing the shaft end of the motor.

**Table 2: Unit Application Data**

Voltage Variation <sup>1</sup> Min. / Max.	208/230-3-60	187/252
	460-3-60	432/504
	575-3-60	540/630
Ambient Air on Condenser Coil Min. /Max.		40°F/125°F <sup>2</sup>
Suction Pressure at Compressor and Corresponding Temp. at Saturation Min. / Max.		106.6 psig / 156.6 psig 32.0 °F / 55.0 °F

1.Utilization range "A" in accordance with AHRI Standard 110.

2.These units can operate in an ambient temperature of 125°F providing the wet bulb temperature of the air entering the evaporator coil does not exceed 67°F. Unit can operate to 0°F if equipped with a low ambient kit.

## Installation

### Preceding Installation

If a factory option convenience outlet is installed, the weatherproof outlet cover must be field installed. The cover shall be located in the unit control box. To install the cover, remove the shipping label covering the convenience outlet, follow the instructions on the back of the weatherproof cover box, and attach the cover to the unit using the (4) screws provided.

### CAUTION

208/230-3-60 and 380/415-3-50 units with factory installed Powered Convenience Outlet Option are wired for 230v and 415v power supply respectively. Change tap on transformer for 208-3-60 or 380-3-50 operation. See unit wiring diagram.

### Limitations

These units must be installed in accordance with all national and local safety codes. If no local codes apply, installation must conform to the appropriate national codes. Units are designed to meet National Safety Code Standards. If components are to be added to a unit to meet local codes, they are to be installed at the dealer's and/or the customer's expense.

## Location

Use the following guidelines to select a suitable location for both the condensing unit and the evaporator.

1. The condensing unit is designed for outdoor installation only.
2. The condenser fans are the propeller type and are not suitable for use with ductwork in the condenser air stream.
3. The condensing unit and the evaporator should be positioned to minimize the number of bends in the refrigerant piping.
4. The condensing unit should be as close to the evaporator as practical.
5. The condensing unit should not be installed where normal operating sounds may be objectionable.
6. The evaporator should be located within the building, either outside or inside the conditioned space.

### Rooftop Locations

Be careful not to damage the roof. Consult the building contractor or architect if the roof is bonded. Choose a location with adequate structural strength to support the unit.

The condensing unit must be mounted on level supports. The supports can be channel iron beams or wooden beams treated to reduce deterioration.

Minimums of two (2) beams are required to support each unit. The beams should: (1) be positioned perpendicular to the roof joists. (2) Extend beyond the dimensions of the section to distribute the load on the roof. (3) Be capable of adequately supporting the concentrated loads at the corners. These beams can usually be set directly on the roof. Flashing is not required.

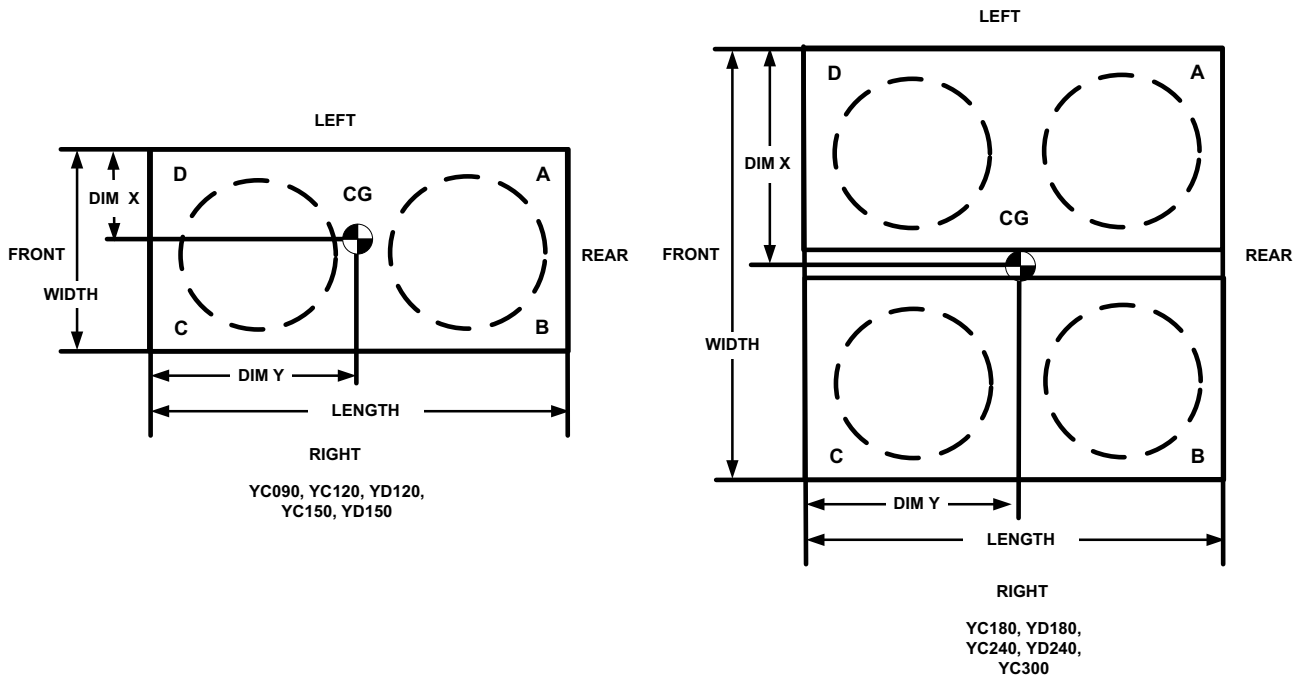
**NOTE:** On bonded roofs, check for special installation requirements.

### Ground Level Locations

It is important that the units be installed on a substantial base that will not settle, causing strain on the refrigerant lines and possible leaks. A one-piece concrete slab with footers that extend below the frost line is recommended. The slab should not be tied to the building foundation, as noise will telegraph through the slab.

**Table 3: Corner Weights & Center of Gravity**

Size (Tons)	Model	Weight (lbs.)		Center of Gravity (in.)		4 Point Load Location (lbs.)			
		Shipping	Operating	X	Y	A	B	C	D
090 (7.5)	YC090	390	387	17	32.3	99	113	94	82
120 (10)	YC120	499	497	17.3	32.3	124	147	122	103
	YD120	493	490	17.4	32.5	123	147	120	100
150 (12.5)	YC150	499	497	17	32.3	127	145	120	105
	YD150	493	490	17.4	32.5	123	147	120	100
180 (15)	YC180	914	909	32.5	31.5	239	246	215	209
	YD180	899	894	32.5	31.5	235	242	212	206
240 (20)	YC240	945	942	30.3	31.0	261	234	212	236
	YD240	930	927	32.7	31.8	244	255	218	210
300 (25)	YC300	945	942	30.3	31.0	261	234	212	236



**Figure 1: Corner Weights & Center Of Gravity**

**NOTE:** Front of unit is considered the side having the unit control box.

Concrete piers can also support ground level units. These piers should (1) extend below the frost line, (2) be located under each of the section's four corners, and (3) be sized to carry the load of the corner it supports.

On either rooftop or ground level installations, rubber padding can be applied under the unit to lessen any transmission of vibration.

Holes are provided in the base rails for bolting the unit to its foundation.

For ground level installations, precautions should be taken to protect the unit from tampering and unauthorized persons from injury. Screws on access panels will prevent casual tampering. Further safety precautions such as a fenced enclosure or locking devices on the panels may be advisable. Check local authorities for safety regulations.

## Clearances

The unit must be installed with sufficient clearance for air to enter the condenser coil, for air discharge and for servicing access. See Table 4 for clearances.

**NOTE:** Additional clearance is required to remove the compressors out the back of the unit, unless a means is available to lift the compressor out through the top of the unit.

**Table 4: Minimum Clearances**

Clearance Description	Distance in Inches
Overhead (Top)	120
Front	36
Rear	36
Left Side	30
Right Side	30
Bottom <sup>1</sup>	0

1. In all installations where snow accumulates and winter operation is expected, additional height must be provided to insure normal condenser airflow.

## WARNING

Do not permit overhanging structures or shrubs to obstruct condenser air discharge.

## Rigging

Exercise care when moving the unit. Do not remove any packaging until the unit is near the place of installation. Rig the unit by attaching chain or cable slings to the lifting holes provided in the base rails. Spreader bars, whose length exceeds the largest dimension across the unit, **MUST** be used across the top of the unit.

The unit may be moved or lifted with a forklift. Slotted openings in the base rails are provided for this purpose.

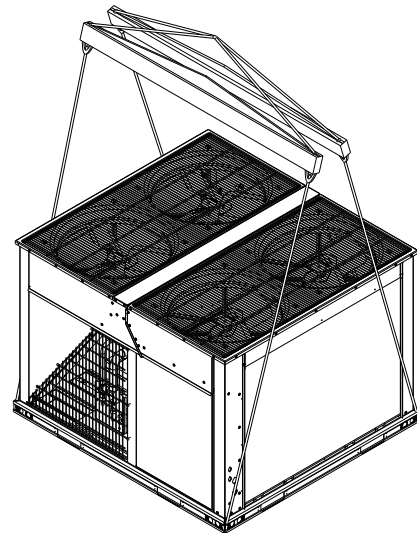
**LENGTH OF FORKS MUST BE A MINIMUM OF 60 INCHES.**

## CAUTION

Spreaders, longer than the largest dimension across the unit must be used across the top of the unit.

## WARNING

Before lifting a unit, make sure that its weight is distributed equally on the cables so that it will lift evenly.



**Figure 2: Typical Rigging**

### Power Wiring

Check the available power and the unit nameplate for correct voltage. Run the necessary number of properly sized wires to the unit. Provide a disconnect switch (if not included with the unit) and fusing as required (factory disconnect is a fused disconnect/breaker). Route the conduit through the large knockout located on the front of the electrical box. See Table 5 for Electrical Data.

The disconnect switch may be bolted to the side of the unit but not to any of the removable panels; this would interfere with access to the unit. Make sure that no refrigerant lines will be punctured when mounting the disconnect switch, and note that it must be suitable for outdoor installation.

### WARNING

All power and control wiring must be in accordance with National and Local electrical codes.

### Control Wiring

Route the necessary low voltage control wires from the Simplicity™ control board to the thermostat and also from the low voltage condenser unit control box to the terminal block inside the evaporator unit. Refer to Figures 3 thru 10 for field wiring diagrams.

### Compressors

The scroll compressors used in this product are specifically designed to operate with R-410A Refrigerant and cannot be interchanged.

### CAUTION

This system uses R-410A Refrigerant which operates at higher pressures than R-22. No other refrigerant may be used in this system.

The compressor also uses a polyolester (POE oil), Mobil 3MA POE. This oil is extremely hygroscopic, meaning it absorbs water readily. POE oil can absorb 15 times as much water as other oils designed for HCFC and CFC refrigerants. Take all necessary precautions to avoid exposure of the oil to the atmosphere.

### CAUTION

Do not leave the system open to the atmosphere. Unit damage could occur due to moisture being absorbed by the **POE oil** in the system. This type of oil is highly susceptible to moisture absorption.

POE (polyolester) compressor lubricants are known to cause long term damage to some synthetic roofing materials.

### CAUTION

Exposure, even if immediately cleaned up, may cause embrittlement (leading to cracking) to occur in one year or more. When performing any service that may risk exposure of compressor oil to the roof, take precautions to protect roofing.

Procedures which risk oil leakage include, but are not limited to, compressor replacement, repairing refrigerant leaks, replacing refrigerant components such as filter drier, pressure switch, metering device or coil.

Units are shipped with compressor mountings which are factory adjusted and ready for operation.

### CAUTION

Do not loosen compressor mounting bolts.

### Phasing

Three-phase, scroll compressors operate in only one direction. If the scroll is drawing low amperage, has similar suction and discharge pressures, or is producing a high noise level, the scroll is misphased. Change the incoming line connection phasing to obtain the proper rotation.

### CAUTION

Scroll compressors require proper rotation to operate properly. Failure to check and correct rotation may result in property damage.



## Electrical Data

**Table 5: Electrical Data - Outdoor Unit - AC Without Powered Convenience Outlet**

Model	Compressors					Outdoor Fan Motor				Pwr Conv Outlet	Minimum Circuit Ampacity <sup>1</sup>	Maximum Fuse Size (A) <sup>2</sup>
	Power Supply	Qty	RLA (each)	MCC (each)	LRA (each)	Power Supply	HP	Qty	FLA (each)	FLA		
YC090	208/230-3-60	1	25.0	39	164	208/230-1-60	1/3	2	2.1	-	35.5	45
	460-3-60	1	12.2	19	100	460-1-60	1/3	2	1.2	-	17.6	25
	575-3-60	1	9.0	14	78	575-1-60	1/3	2	0.9	-	13.1	20
YC120	208/230-3-60	2	18.1	28.3	137	208/230-1-60	3/4	2	3.0	-	46.8	60
	460-3-60	2	9.0	14.0	62	460-1-60	3/4	2	1.6	-	23.5	30
	575-3-60	2	6.8	10.6	50	575-1-60	3/4	2	1.4	-	18.0	20
YD120	208/230-3-60	2	17.3	27	123	208/230-1-60	3/4	2	3.0	-	45.0	60
	460-3-60	2	9.6	15	70	460-1-60	3/4	2	1.6	-	24.8	30
	575-3-60	2	7.7	12	53	575-1-60	3/4	2	1.4	-	20.0	25
YC150	208/230-3-60	2	22.4	35	149	208/230-1-60	3/4	2	3.0	-	56.5	70
	460-3-60	2	10.6	17	75	460-1-60	3/4	2	1.6	-	27.1	35
	575-3-60	2	7.7	12	54	575-1-60	3/4	2	1.4	-	20.0	25
YD150	208/230-3-60	2	23.1	36	160	208/230-1-60	3/4	2	3.0	-	58.0	80
	460-3-60	2	12.2	19	87	460-1-60	3/4	2	1.6	-	30.7	40
	575-3-60	2	8.7	14	62	575-1-60	3/4	2	1.4	-	22.3	30
YC180	208/230-3-60	2	25.0	39	164	208/230-1-60	1/3	4	2.1	-	64.7	80
	460-3-60	2	12.2	19	100	460-1-60	1/3	4	1.2	-	32.2	40
	575-3-60	2	9.0	14	78	575-1-60	1/3	4	0.9	-	24.0	30
YD180	208/230-3-60	2	25.0	39	164	208/230-1-60	1/3	4	2.1	-	64.7	80
	460-3-60	2	12.2	19	100	460-1-60	1/3	4	1.2	-	32.2	40
	575-3-60	2	9.0	14	78	575-1-60	1/3	4	0.9	-	24.0	30
YC240	208/230-3-60	2	30.1	47	225	208/230-1-60	3/4	4	3.0	-	79.8	100
	460-3-60	2	16.7	26	114	460-1-60	3/4	4	1.6	-	44.0	60
	575-3-60	2	12.2	19	80	575-1-60	3/4	4	1.4	-	32.9	45
YD240	208/230-3-60	2	30.1	47	225	208/230-1-60	3/4	4	3.0	-	79.8	100
	460-3-60	2	16.7	26	114	460-1-60	3/4	4	1.6	-	44.0	60
	575-3-60	2	12.2	19	80	575-1-60	3/4	4	1.4	-	32.9	45
YC300	208/230-3-60	2	48.1	75	245	208/230-1-60	3/4	4	3.0	-	120.3	150
	460-3-60	2	18.6	29	125	460-1-60	3/4	4	1.6	-	48.3	60
	575-3-60	2	14.7	23	100	575-1-60	3/4	4	1.4	-	38.5	50

1. Based on three, 75°C insulated copper conductors in conduit and ambient of 30°C.

2. Maximum fuse or maximum circuit breaker (HACR type per NEC).

Refer to NEC/NFPA No. 70, Articles 440-11, 12 for information on minimum disconnect sizing.

**Table 6: Electrical Data - Outdoor Unit - AC With Powered Convenience Outlet**

Model	Compressors					Outdoor Fan Motor				Pwr Conv Outlet	Minimum Circuit Ampacity <sup>1</sup>	Maximum Fuse Size (A) <sup>2</sup>
	Power Supply	Qty	RLA (each)	MCC (each)	LRA (each)	Power Supply	HP	Qty	FLA (each)	FLA		
YC090	208/230-3-60	1	25.0	39	164	208/230-1-60	1/3	2	2.1	10.0	45.5	60
	460-3-60	1	12.2	19	100	460-1-60	1/3	2	1.2	5.0	22.6	30
	575-3-60	1	9.0	14	78	575-1-60	1/3	2	0.9	4.0	17.1	25
YC120	208/230-3-60	2	18.1	28.3	137	208/230-1-60	3/4	2	3.0	10.0	56.8	70
	460-3-60	2	9.0	14.0	62	460-1-60	3/4	2	1.6	5.0	28.5	35
	575-3-60	2	6.8	10.6	50	575-1-60	3/4	2	1.4	4.0	22.0	25
YD120	208/230-3-60	2	17.3	27	123	208/230-1-60	3/4	2	3.0	10.0	55.0	70
	460-3-60	2	9.6	15	70	460-1-60	3/4	2	1.6	5.0	29.8	35
	575-3-60	2	7.7	12	53	575-1-60	3/4	2	1.4	4.0	24.0	30
YC150	208/230-3-60	2	22.4	35	149	208/230-1-60	3/4	2	3.0	10.0	66.5	80
	460-3-60	2	10.6	17	75	460-1-60	3/4	2	1.6	5.0	32.1	40
	575-3-60	2	7.7	12	54	575-1-60	3/4	2	1.4	4.0	24.0	30
YD150	208/230-3-60	2	23.1	36	160	208/230-1-60	3/4	2	3.0	10.0	68.0	90
	460-3-60	2	12.2	19	87	460-1-60	3/4	2	1.6	5.0	35.7	45
	575-3-60	2	8.7	14	62	575-1-60	3/4	2	1.4	4.0	26.3	30
YC180	208/230-3-60	2	25.0	39	164	208/230-1-60	1/3	4	2.1	10.0	74.7	90
	460-3-60	2	12.2	19	100	460-1-60	1/3	4	1.2	5.0	37.2	45
	575-3-60	2	9.0	14	78	575-1-60	1/3	4	0.9	4.0	28.0	35
YD180	208/230-3-60	2	25.0	39	164	208/230-1-60	1/3	4	2.1	10.0	74.7	90
	460-3-60	2	12.2	19	100	460-1-60	1/3	4	1.2	5.0	37.2	45
	575-3-60	2	9.0	14	78	575-1-60	1/3	4	0.9	4.0	28.0	35
YC240	208/230-3-60	2	30.1	47	225	208/230-1-60	3/4	4	3.0	10.0	89.8	110
	460-3-60	2	16.7	26	114	460-1-60	3/4	4	1.6	5.0	49.0	60
	575-3-60	2	12.2	19	80	575-1-60	3/4	4	1.4	4.0	36.9	45
YD240	208/230-3-60	2	30.1	47	225	208/230-1-60	3/4	4	3.0	10.0	89.8	110
	460-3-60	2	16.7	26	114	460-1-60	3/4	4	1.6	5.0	49.0	60
	575-3-60	2	12.2	19	80	575-1-60	3/4	4	1.4	4.0	36.9	45
YC300	208/230-3-60	2	48.1	75	245	208/230-1-60	3/4	4	3.0	10.0	130.3	175
	460-3-60	2	18.6	29	125	460-1-60	3/4	4	1.6	5.0	53.3	70
	575-3-60	2	14.7	23	100	575-1-60	3/4	4	1.4	4.0	42.5	50

1. Based on three, 75°C insulated copper conductors in conduit and ambient of 30°C.

2. Maximum fuse or maximum circuit breaker (HACR type per NEC).  
Refer to NEC/NFPA No. 70, Articles 440-11, 12 for information on minimum disconnect sizing.

## Refrigerant Mains

### CAUTION

This Split-System (Air Condensing / Heat Pump / Air Handling) unit is one component of an entire system. As such it requires specific application considerations with regard to the rest of the system (air handling unit, duct design, condensing unit, refrigerant piping and control scheme).

Failure to properly apply this equipment with the rest of the system may result in premature failure and/or reduced performance / increased costs. Warranty coverage specifically excludes failures due to improper application and Unitary Products specifically disclaims any liability resulting from improper application.

Please refer to the equipment Technical Guide, Installation Manual and the piping applications bulletin 247077 or call the applications department for Unitary Products @ 1-877-UPG-SERV for guidance.

### Line Sizing

When sizing refrigerant pipe for a split-system air conditioner, check the following:

1. Suction line pressure drop due to friction.
2. Liquid line pressure drop due to friction.
3. Suction line velocity for oil return.
4. Liquid line pressure drop due to vertical rise. For certain piping arrangements, different sizes of suction line pipe may have to be used. The velocity of the refrigerant vapor must always be great enough to carry the oil back to the compressor.
5. **Evaporator Located Below Condenser** - On a split system where the evaporator blower is located below the condenser, the suction line must be sized for both pressure drop and for oil return.
6. **Condenser Located Below Evaporator** - When the condenser is located below the evaporator blower, the liquid line must be designed for the pressure drop due to both friction loss and vertical rise. If the pressure drop due to vertical rise and friction exceeds 60 psi, some refrigerant will flash before it reaches the thermal expansion valve.

### Flash gas:

1. Increases the liquid line pressure loss due to friction that in turn causes further flashing.
2. Reduces the capacity of the refrigerant control device which starves the evaporator.
3. Erodes the seat of the refrigerant control device.
4. Causes erratic control of the refrigerant entering the evaporator.

### Take Adequate Precautions

Many service problems can be avoided by taking adequate precautions to provide an internally clean and dry system and by using procedures and materials that conform to established standards.

Use hard drawn copper tubing where no appreciable amount of bending around pipes or other obstructions is necessary. If soft copper is used, care should be taken to avoid sharp bends that may cause a restriction. Pack fiberglass insulation and a sealing material such as permagum around refrigerant lines where they penetrate a wall to reduce vibrations and to retain some flexibility.

Support all tubing at minimum intervals with suitable hangers, brackets or clamps.

Braze all copper-to-copper joints with Silfos-5 or equivalent brazing material. Do not use soft solder. Insulate all suction lines with a minimum of 1/2" ARMAFLEX or equivalent that meets local codes. Liquid lines exposed to direct sunlight and/or high temperatures must also be insulated. Never solder suction and liquid lines together. They can be taped together for convenience and support purposes, but they must be completely insulated from each other.

The liquid and suction service ports on the condenser section permit leak testing, evacuation, and partial charging of the field piping and the evaporator without disturbing refrigerant stored in the condenser during initial installation.

Before beginning installation of the main lines, be sure that the evaporator section has not developed a leak in transit. Check pressure at the Schrader valve located on the header of each coil. If pressure still exists in the system, it can be assumed to be leak free. If pressure DOES NOT exist the section will need to be repaired before evacuation and charging is performed.

A filter-drier MUST be field-installed in the liquid line of every system to prevent dirt and moisture from damaging the system. Properly sized filter-driers are shipped with each condensing section.

**NOTE:** Installing a filter-drier does not eliminate the need for the proper evacuation of a system before it is charged.

A field-installed moisture indicating sight-glass should be installed in the liquid line(s) between the filter-drier and the evaporator coil. The moisture indicating sight-glass can be used to check for excess moisture in the system.

Both condenser and evaporator sections have copper sealing disks brazed over the end of liquid and suction connections. The temperature required to make or break a brazed joint is high enough to cause oxidation of the copper unless an inert atmosphere is provided.

**NOTE:** Dry nitrogen should flow through the system at all times when heat is being applied and until the joint has

cooled. The flow of nitrogen will prevent oxidation of the copper lines during installation.

Always punch a small hole in sealing disks before unbrazing to prevent the pressure in the line from blowing them off. Do not use a drill as copper shavings can enter system.

**NOTE:** Solenoid and hot gas bypass valves (if used) should be opened manually or electrically during brazing or evacuating.

**NOTE:** Schrader valves located on unit service valves should have their stem removed during brazing to prevent damage to the valve.

### Start Installation

Start Installation of main lines at the condenser unit. Verify the service valves are fully seated by screwing the stem of both valves down into the valve body until it stops. Remove the Schrader valve stem and connect a low-pressure nitrogen source to the service port on the suction line valve body. Punch a small hole in the sealing disk; the flow of nitrogen will prevent any debris from entering the system. Wrap the valve body with a wet rag to prevent overheating during the brazing process. Overheating the valve will damage the valve seals. Unbrazing the sealing disk, cool the valve body and prepare the joint for connections of the main lines. Repeat for the liquid line valve body.

#### WARNING

Never remove a cap from an access port unless the valve is fully back-seated with its valve stem in the maximum counter-clockwise position because the refrigerant charge will be lost. Always use a refrigeration valve wrench to open and close these service valves.

Connect the main liquid line to the liquid line service valve on the condenser section, while maintaining a flow of nitrogen. Cool the valve body and replace the Schrader valve stem on the service port of the liquid line service valve.

Install the liquid line from the condenser unit to the evaporator liquid connection, maintaining a flow of nitrogen during all brazing operations.

The filter-drier and sight glass must be located in this line, leaving the O.D. unit.

Connect a low-pressure nitrogen source to the Schrader valve located on the evaporator unit coil headers. Punch a small hole in the sealing disks, the flow of nitrogen will prevent any debris from entering the system. Unbrazing both liquid and suction

sealing disks and prepare the joints for connections of the main lines.

Connect the main liquid line to the liquid line connection on the evaporator unit, while maintaining a flow of nitrogen.

Make the suction line connection at the evaporator and run the line to the condenser unit. Connect the main suction line to the suction line service line on the condenser unit, while maintaining a flow of nitrogen. Cool the valve body and replace the Schrader valve stem on the service port of the suction line service valve.

Once the brazing process is complete, leak testing should be done on all interconnecting piping and the evaporator before proper evacuation to 500 microns is performed. Once the line set and evaporator unit is properly evacuated the service valves can be opened and the condenser unit is now ready to charge with the appropriate weight of refrigerant.

Calculate the correct system charge for the condenser unit, the evaporator unit and the field line set. Charge the system by introducing liquid refrigerant into the liquid line through the liquid port connection. Complete adding the refrigerant in vapor form into the suction port when the compressor is started.

The correct refrigerant pressures are indicated as shown in Figures 15 through 24.

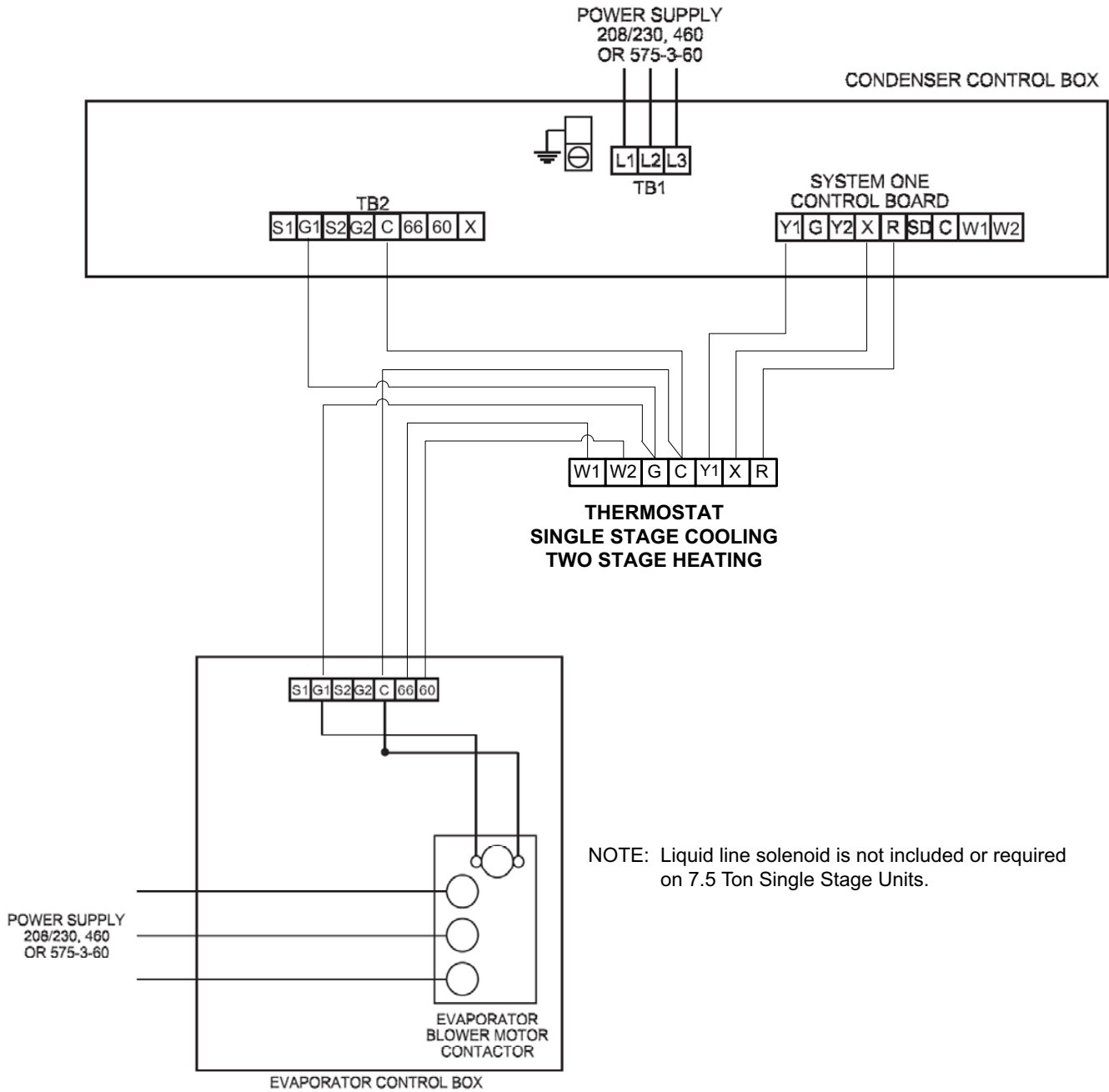
#### CAUTION

This system uses R-410A Refrigerant which operates at higher pressures than R-22. No other refrigerant may be used in this system. Gage sets, hoses, refrigerant containers and recovery systems must be designed to handle R-410A. If you are unsure, consult the equipment manufacturer. Failure to use R-410A compatible servicing equipment may result in property damage or injury.

#### WARNING

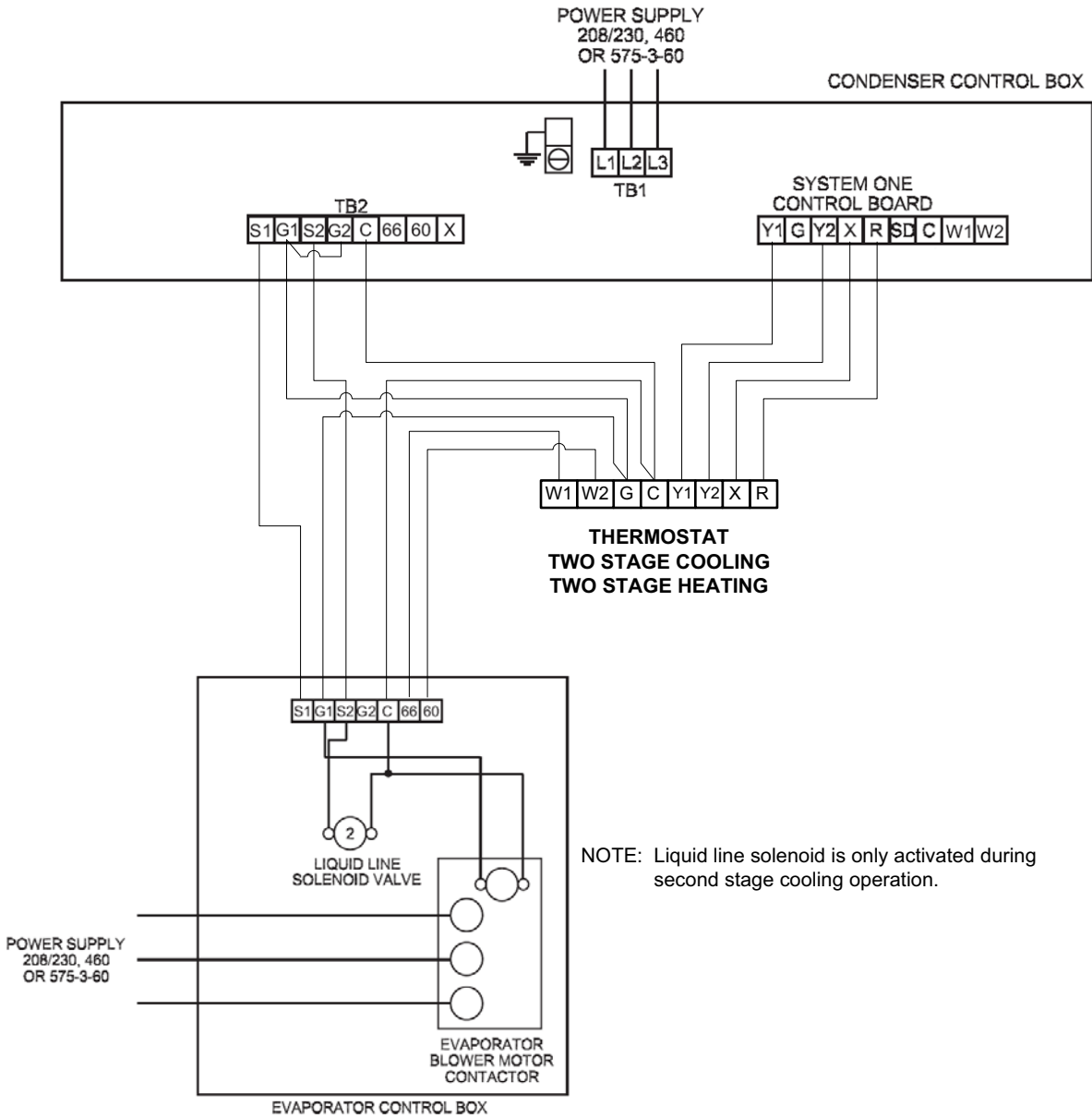
Wear safety glasses and gloves when handling refrigerants. Failure to follow this warning can cause serious personal injury.

**NOTE:** This instruction covers the installation and operation of the basic condenser unit. For refrigerant piping installation instructions refer to document 247077 "Application Data - General Piping Recommendations for Split System Air Conditioning and Heat Pumps".



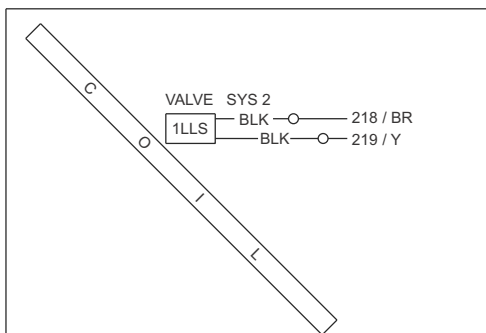
**Figure 3: Typical Field Wiring Diagram - NC90 Evaporator Unit with YC90 Condenser Unit**

**NOTE:** On non NC/ND Evaporator models, isolation relays must be installed to avoid overloading on 75 VA transformers on the condensing unit.

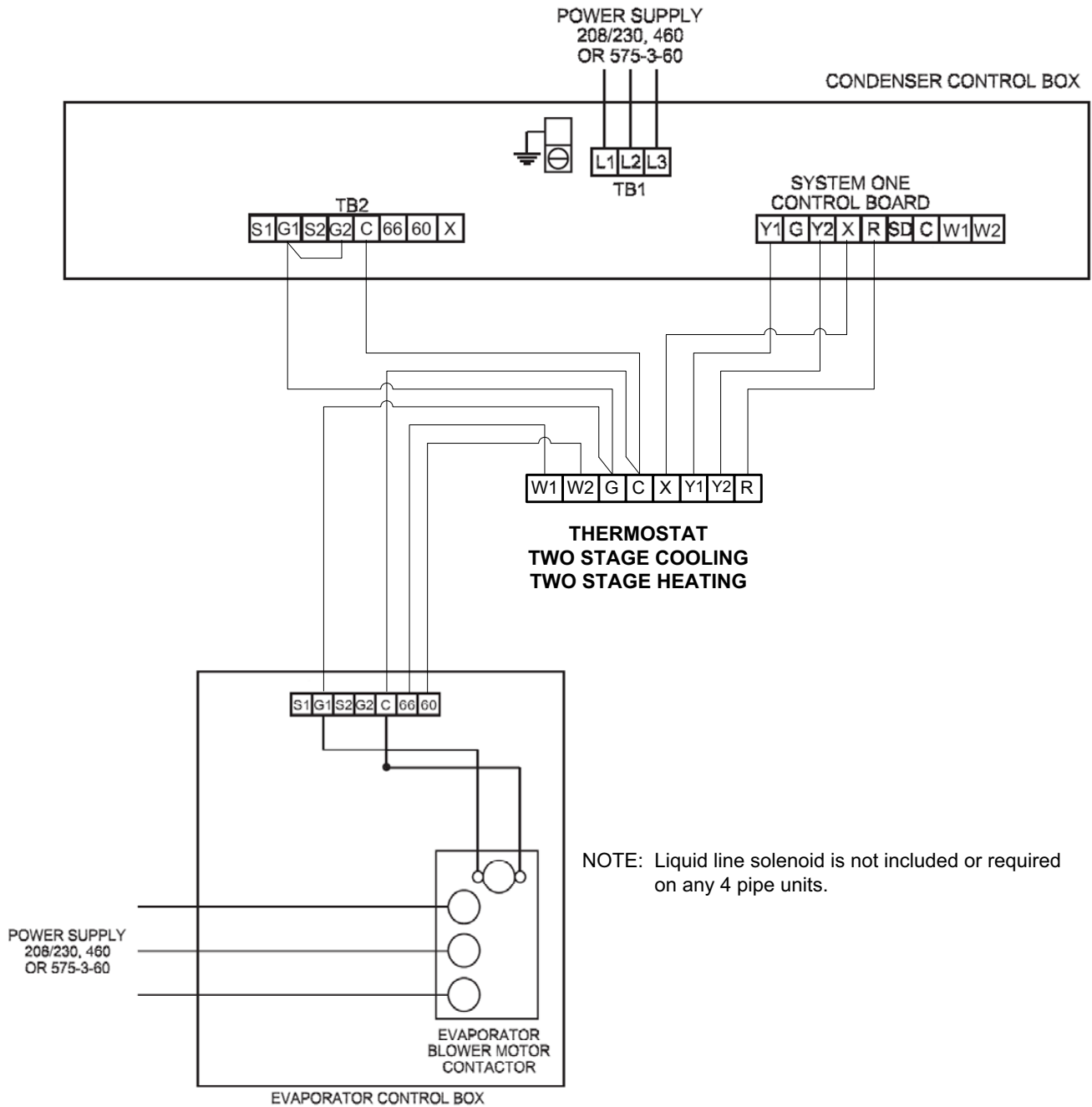


**Figure 4: Typical Field Wiring Diagram - NC120 thru 240 Evaporator Unit with YC120 thru 240 Condenser Unit**

**NOTE:** On non NC/ND Evaporator models, isolation relays must be installed to avoid overloading on 75 VA transformers on the condensing unit.

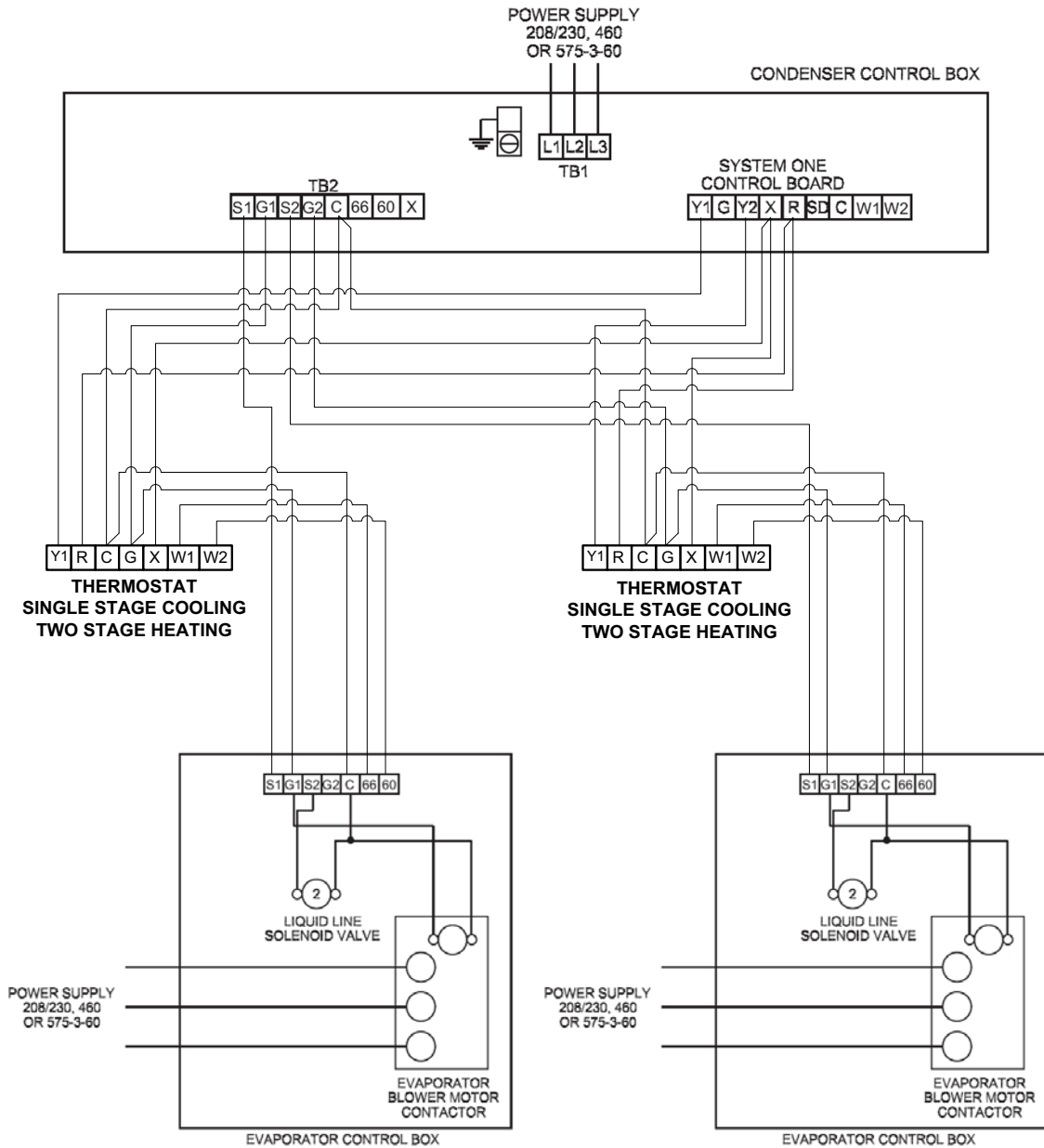


**Figure 5: NC120 - 240 Liquid Line Solenoid Wiring**



**Figure 6: Typical Field Wiring Diagram - ND120 thru 240 Evaporator Unit with YD120 thru 240 Condenser Unit**

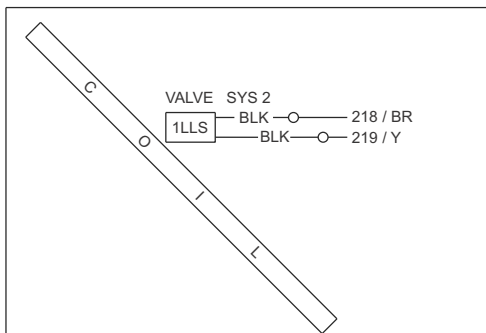
**NOTE:** On non NC/ND Evaporator models, isolation relays must be installed to avoid overloading on 75 VA transformers on the condensing unit.



**Figure 7: Typical Field Wiring Diagram - Twin NC120 thru 240 Evaporator Units with 4-Pipe Condenser Unit**

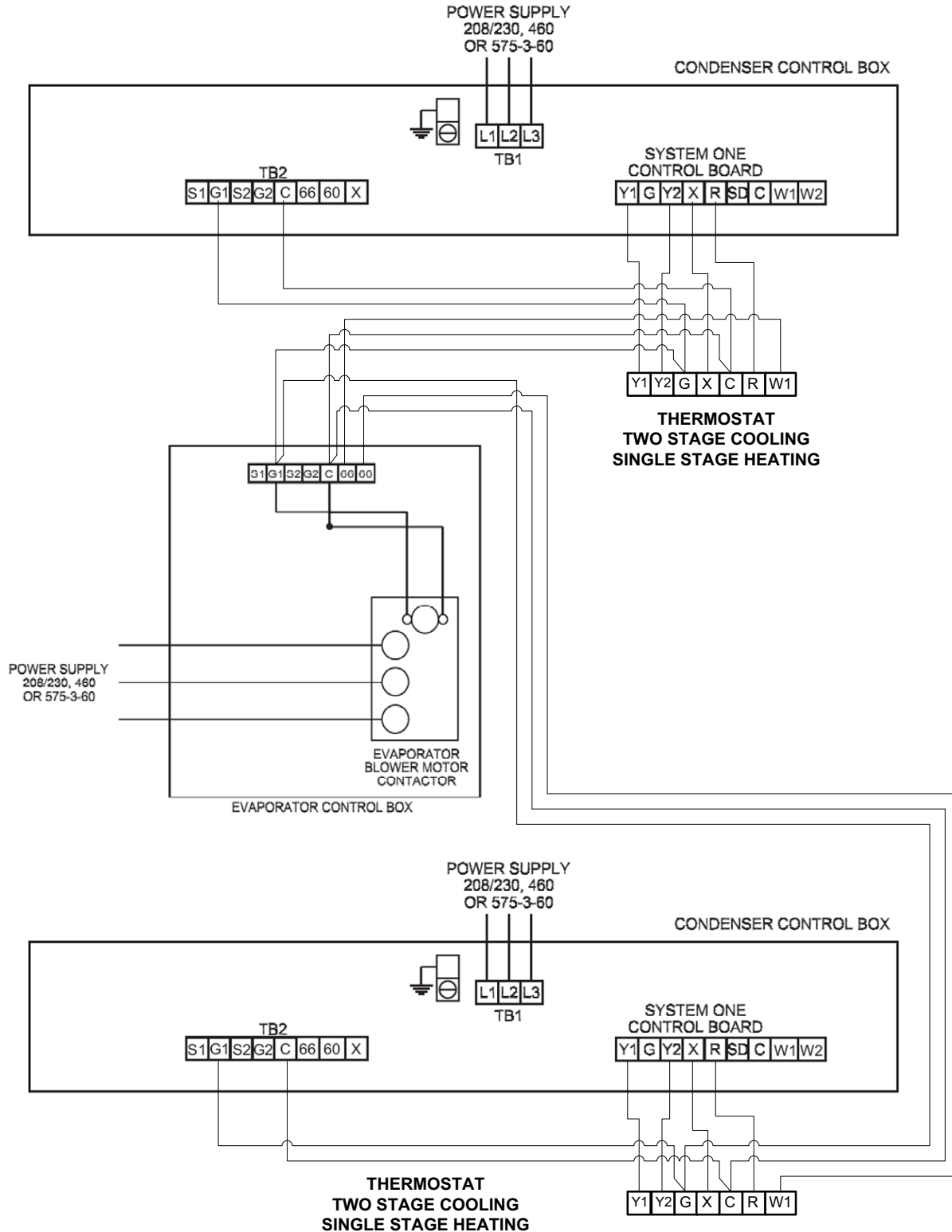
**NOTE:** On non NC/ND Evaporator models isolation relays must be installed to avoid overloading on 75 VA transformer on the condensing unit.

**NOTE:** Refer to Evaporator unit wiring diagram for control of liquid line solenoid valve.



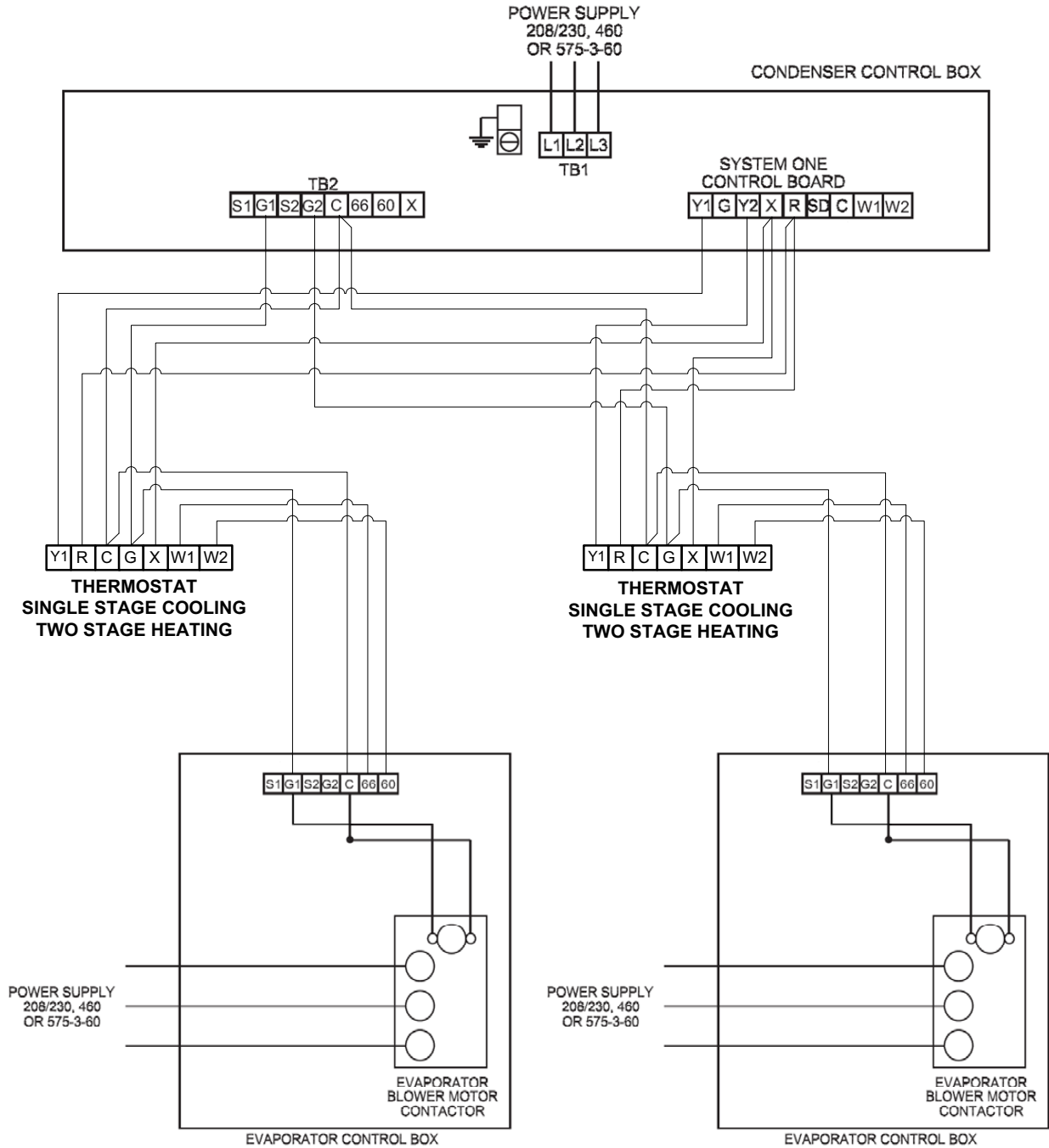
**Figure 8: NC120 - 240 Liquid Line Solenoid Wiring**





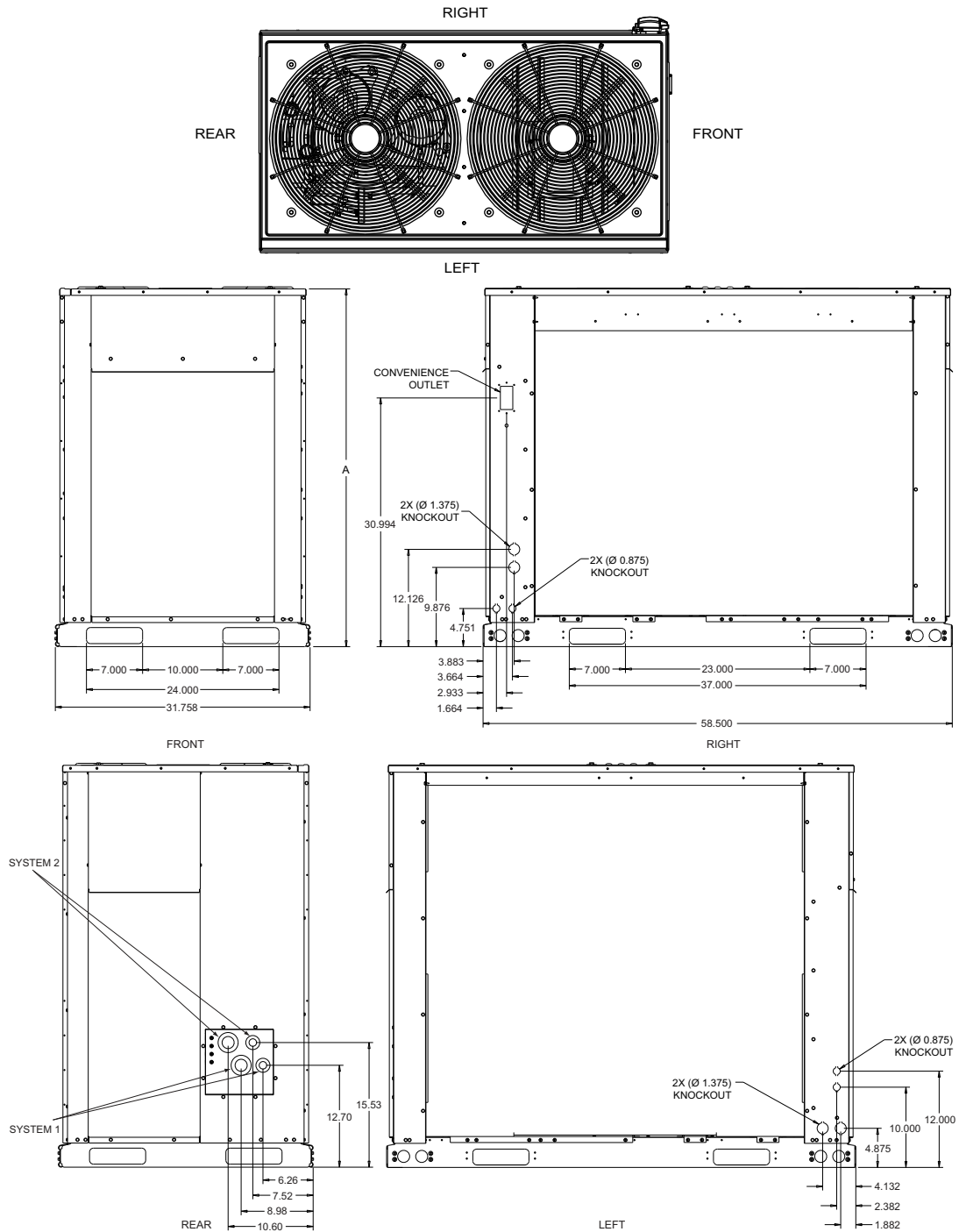
**Figure 9: Typical Field Wiring Diagram - Single 4-Pipe Evaporator Unit with Twin Condenser Units**

**NOTE:** On non NC/ND Evaporator models, isolation relays must be installed to avoid overloading on 75 VA transformers on the condensing unit.



**Figure 10: Typical Field Wiring Diagram - Twin NC090 Evaporator Units with YD180 Condenser Unit**

**NOTE:** On non NC/ND Evaporator models, isolation relays must be installed to avoid overloading on 75 VA transformers on the condensing unit.



**Figure 11: YC090, YC/YD120, YC/YD150 Unit Dimensions**

**NOTE:** Use a System 1 piping dimensions when applying a YC09/120/150 model system.

**Table 7: YC090, YC/YD120, YC/YD150 Unit Height Dimensions**

MODEL	A
YC090	44.5
YC120	50.0
YD120	50.0
YC150	50.0
YD150	50.0

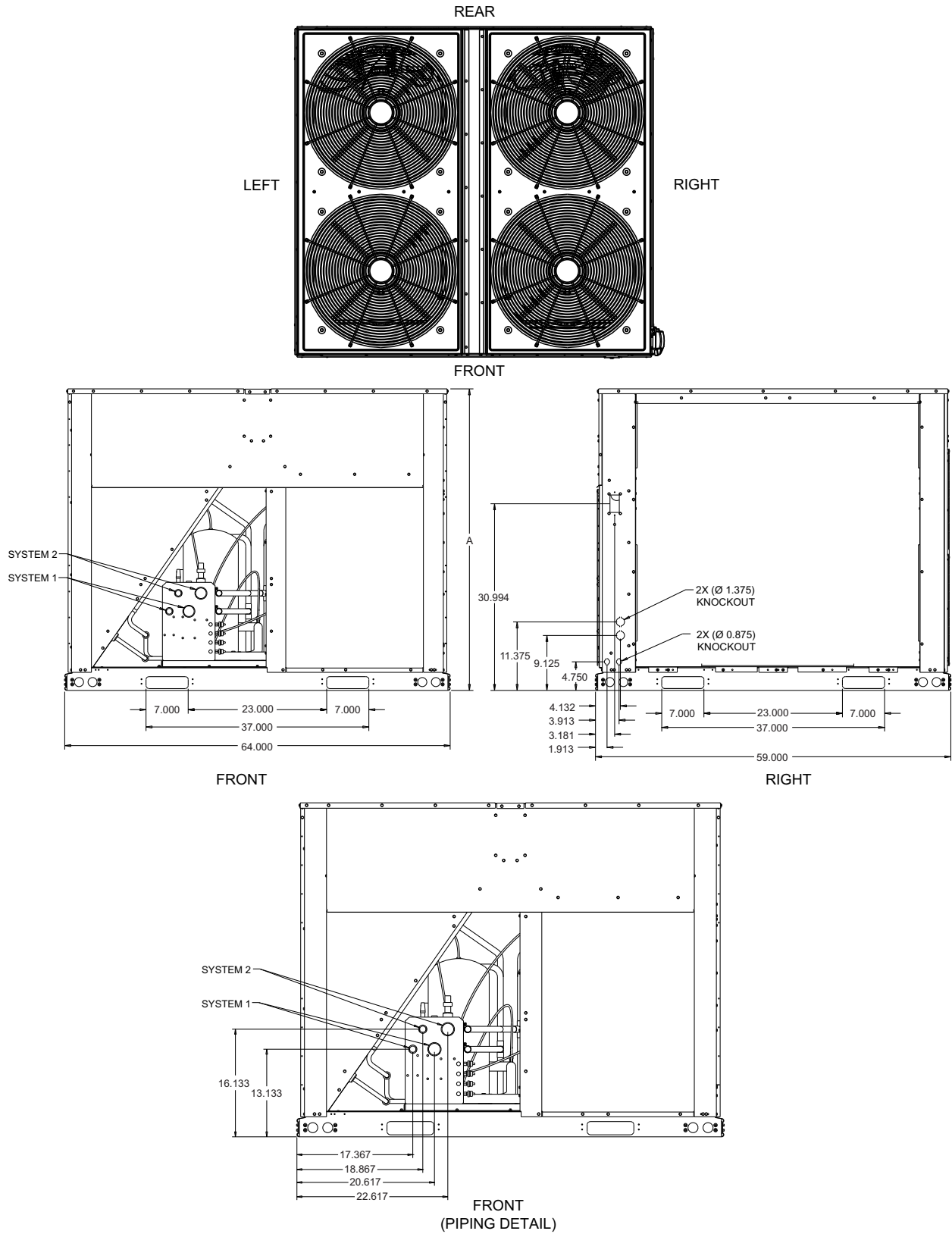


Figure 12: YC/YD180, YC/YD240 & YC300 Unit Dimensions and Piping & Electrical Dimensions

NOTE: Use System 1 piping dimensions when applying a YC180/240/300 model system.

**Table 8: YC/YD180, YC/YD240 and YC300 Unit Height Dimensions**

MODEL	A
YC180	44.5
YD180	44.5
YC240	50.0
YD240	50.0
YC300	50.0

**Table 9: Piping And Electrical Connection Sizes (Inches)**

MODEL	YC090	YC120	YD120	YC150	YD150
No. Refrigeration Circuits	1	1	2	1	2
Suction Line OD (in.)	1 1/8	1 3/8	1 1/8	1 3/8	1 1/8
Liquid Line OD (in.)	5/8	7/8	5/8	7/8	5/8
Power Wiring Knockout	1 3/8	1 3/8	1 3/8	1 3/8	1 3/8
Control Wiring Knockout	7/8	7/8	7/8	7/8	7/8

MODEL	YC180	YD180	YC240	YD240	YC300
No. Refrigeration Circuits	1	2	1	2	1
Suction Line OD (in.)	1 5/8	1 3/8	1 5/8	1 3/8	1 5/8
Liquid Line OD (in.)	7/8	5/8	7/8	5/8	7/8
Power Wiring Knockout	1 3/8	1 3/8	1 3/8	1 3/8	1 3/8
Control Wiring Knockout	7/8	7/8	7/8	7/8	7/8

## Piping And Electrical Connections

Piping connections are made from the rear of 7.5 thru 12.5 Ton units and the front of 15 thru 25 Ton units. Connections can be made directly to the suction and liquid line service valves. Piping can be routed to the units from the left or right side.

Electrical connections for power and control wiring are made from the right or left side of all units. See Table 15 and Figures 8 and 11 for piping sizes and electrical knockout details.

## Start-Up

### Crankcase Heater

The crankcase heater must be energized at least 8 hours before starting the compressor. To energize the crankcase heater, the main disconnect switch must be closed. During this 8 hour period, the system switch on the room thermostat must be "OFF" to prevent the compressor from starting. Make sure that the bottom of the compressor is warm to the touch to prove crankcase heater operation.

### CAUTION

Do not attempt to start the compressor without at least 8 hours of crankcase heat or compressor damage can occur.

## Pre-Start Check

Before starting the unit, complete the following check list:

1. Have sufficient clearances been provided?
2. Has all foreign matter been removed from the interior of the unit (tools, construction or shipping materials, etc.)?
3. Have the condenser fans been rotated manually to check for free rotation?
4. Are all wiring connections tight?
5. Does the available power supply agree with the nameplate data on the unit?
6. Is the control circuit transformer set for the proper voltage?
7. Have the fuses, disconnect switch and power wire been sized properly?
8. Are all compressor hold-down nuts properly secured?
9. Are any refrigerant lines touching each other or any sheet metal surface? Rubbing due to vibration could cause a refrigerant leak.
10. Are there any visible signs of a refrigerant leak, such as oil residue?
11. Has the refrigeration system been leak checked, evacuated and had the correctly calculated charge weighted in?
12. Is any electrical wire laying against a hot refrigerant line?

## Initial Start-Up

1. Supply power to the unit through the disconnect switch at least 8 hours prior to starting the compressor.

2. Move the system switch on the thermostat to the AUTO or COOL position.
3. Reduce the setting of the room thermostat to energize the compressor.
4. Check the operation of the evaporator unit per the manufacturer's recommendations.
5. With an ammeter, check the compressor amps against the unit data plate.
6. Check for refrigerant leaks.
7. Check for any abnormal noises and/or vibrations, and make the necessary adjustments to correct fan blade(s) touching shroud, refrigerant lines hitting on sheet metal, etc.
8. After the unit has been operating for several minutes, shut off the main power supply at the disconnect switch and inspect all factory wiring connections and bolted surfaces for tightness.

## Operation

### Unit Control Overview

These series of condenser unit, come factory equipped with Simplicity™ controls to monitor all unit functionality and safety controls.

### Safety Controls

The Simplicity™ control board incorporates features to monitor safety circuits as well as minimize compressor wear and damage. An anti-short cycle delay (ASCD) is utilized to prevent operation of a compressor too soon after its previous run. Additionally, a minimum run time is imposed anytime a compressor is energized to allow proper oil return to the compressor. The ASCD is initiated on unit start-up and on any compressor reset or lockout.

The Simplicity™ control board monitors the following inputs for each cooling system:

- A high-pressure switch is factory installed to protect against excessive discharge pressure due to a blocked condenser coil or a condenser fan motor failure. During cooling operation, if a high-pressure limit switch opens, the Simplicity™ control board will de-energize the associated compressors and initiate the 5-minute ASCD. If the call for cool is still present at the end of the ASCD, the control board will re-energize the halted compressor. If a high-pressure switch opens three times within two hours of operation, the Simplicity™ control board will lockout the associated system compressors and will flash an error code (See Table 11).
- A low-pressure switch to protect the unit against excessively low suction pressure is standard on all condensing units. If the low-pressure switch opens during normal operation, the Simplicity™ control board will de-energize the compressor, initiate the ASCD, and shut

down the condenser fans. On startup, if the low-pressure switch opens, the Simplicity™ control board will monitor the low-pressure switch to make sure it closes within one minute. If it fails to close, the unit will shut down the associated compressor and begin an ASCD. If the call for cool is still present at the end of the anti-short cycle time delaying, the control board will re-energize the halted compressor. If a low-pressure switch opens three times within one hour of operation, the Simplicity™ control board will lock-out the associated compressor and flash an error code (See Table 11).

- An ambient air switch will lock out mechanical cooling at 40°F. A factory equipped low ambient option allows the unit to operate down to 0°F. A field installed low ambient kit is also available.

The refrigerant systems are independently monitored and controlled. On any fault, only the associated system will be affected by any safety/preventive action. The other refrigerant system will continue to operate unless it is affected by the fault as well.

### Sequence of Operation

#### Continuous Blower

By setting the room thermostat to "ON," the low voltage control circuit from the "R" to "G" is completed and the supply air blower will operate continuously.

#### Intermittent Blower

With the room thermostat fan switch set to "AUTO" and the system switch set to either the "AUTO" or "HEAT" settings, the blower is energized whenever a cooling or heating operation is requested. The blower is energized after any specified delay associated with the operation.

When energized in cooling mode, the indoor blower has a minimum run time of 30 seconds. Additionally, the indoor blower has a delay of 10 seconds between operations.

### Cooling Sequence Of Operation

#### Single-Stage Condenser Unit (YC090)

A single stage cooling thermostat is required to operate the condenser unit.

When the thermostat calls for cooling (Y1), the Simplicity control board (UCB) closes the coils of relay RY1 and contactors M1 and M3.

- Relay RY1 controls the crankcase heater (CCH1). The normally closed contacts allow CCH1 to operate during unit shutdown.
- Contactor M1 controls compressor COMPR1.
- Contactor M3 controls outdoor fans ODFAN1 & 2.

After completing the specified time for fan on-delay, UCB closes the coil of relay BR1.

- Relay BR1 sends a 24V signal to G1 of terminal block TB2. It may be used to control operation of an indoor blower.

When the call for cooling (Y1) is satisfied, the UCB disables the signal to RY1, M1 and M3 as long as the specified minimum run time (ASCD) has elapsed.

The UCB disables the signal to BR1 after completing the fan off-delay period.

### Dual Stage Condenser Unit (YC120-300 or YD120-150)

A two stage cooling thermostat is required to operate the condenser unit.

- When the thermostat calls for first-stage cooling (Y1), the Simplicity control board (UCB) closes the coils of relays RY1 and BR1 and contactor M1.
- Relay RY1 has three functions. 1) control the crankcase heater CCH1, 2) control the coil of contactor M3 and 3) control the 24V output signal to S1 on terminal block TB2.
- Relay BR1 sends a 24V signal to G1 of terminal block TB2. It may be used to control operation of an indoor blower.
- Contactor M1 controls compressor COMPR1.
- Contactor M3 controls all outdoor fans.

When the thermostat calls for second-stage cooling (Y2), the Simplicity control board (UCB) closes the coils of relays RY2 and BR2 and contactor M2.

- Relay RY2 has three functions. 1) control the crankcase heater CCH2, 2) control the coil of contactor M3 and 3) control the 24V output signal to S2 on terminal block TB2.
- Relay BR2 sends a 24V signal to G2 of terminal block TB2. It may be used to control operation of an indoor blower.
- Contactor M2 controls compressor COMPR2.

If the initial call for cooling requires both stages (Y1 and Y2), the UCB will delay the second stage by 30 seconds to avoid an excessive power inrush.

**NOTE:** For lead-lag compressor operation, the jumper between terminals G1 and G2 on terminal block TB2 must remain in place to assure proper blower operation.

When the call for cooling (Y2) is satisfied, the UCB disables the signal to RY2, BR2, and M2 as long as the specified minimum run time (ASCD) has elapsed.

When the call for cooling (Y1) is satisfied, the UCB disables the signal to RY1, BR1 and M1 as long as the specified minimum run time (ASCD) has elapsed.

### Dual Stage Condenser Unit (YD180-240)

A two stage cooling thermostat is required to operate the condenser unit.

When the thermostat calls for first-stage cooling (Y1), the Simplicity control board (UCB) closes the coils of relays RY1 and BR1 and contactor M1.

- Relay RY1 has three functions. 1) control the crankcase heater CCH1, 2) control the coil of contactor M3 and 3) control the 24V output signal to S1 on terminal block TB2.
- Relay BR1 sends a 24V signal to G1 of terminal block TB2. It may be used to control operation of an indoor blower.
- Contactor M1 controls compressor COMPR1.
- Contactor M3 controls outdoor fans ODFAN1 & 2.

When the thermostat calls for second-stage cooling (Y2), the Simplicity control board (UCB) closes the coils of relays RY2 and BR2 and contactor M2.

- Relay RY2 has three functions. 1) control the crankcase heater CCH2, 2) control the coil of contactor M4 and 3) control the 24V output signal to S2 on terminal block TB2.
- Relay BR2 sends a 24V signal to G2 of terminal block TB2. It may be used to control operation of an indoor blower.
- Contactor M2 controls compressor COMPR2.
- Contactor M4 controls outdoor fans ODFAN3 & 4.

If the initial call for cooling requires both stages (Y1 and Y2), the UCB will delay the second stage by 30 seconds to avoid an excessive power inrush.

**NOTE:** For lead-lag compressor operation, the jumper between terminals G1 and G2 on terminal block TB2 must remain in place to assure proper blower operation.

When the call for cooling (Y2) is satisfied, the UCB disables the signal to RY2, BR2, and M2 as long as the specified minimum run time (ASCD) has elapsed.

When the call for cooling (Y1) is satisfied, the UCB disables the signal to RY1, BR1 and M1 as long as the specified minimum run time (ASCD) has elapsed.

### Low Ambient Cooling

These units are factory equipped with low ambient switches that work through the Simplicity control board to operate the compressors and condenser fans normally to 40°F ambient temperature. The Electronic Low Ambient Controller 2LA04703000 Accessory is designed to assure safe operation through condenser head pressure regulation down to 0°F ambient temperature.

#### Low Ambient Control Operation

- A call for cooling closes contactor M3 which energizes all condenser fans. The Low Ambient Control starts all fans at full speed then adjusts according to the liquid line temperature.

Refer to the appropriate 2LA low ambient kit instructions for additional detail on the factory or field installed low ambient kit and its operation.

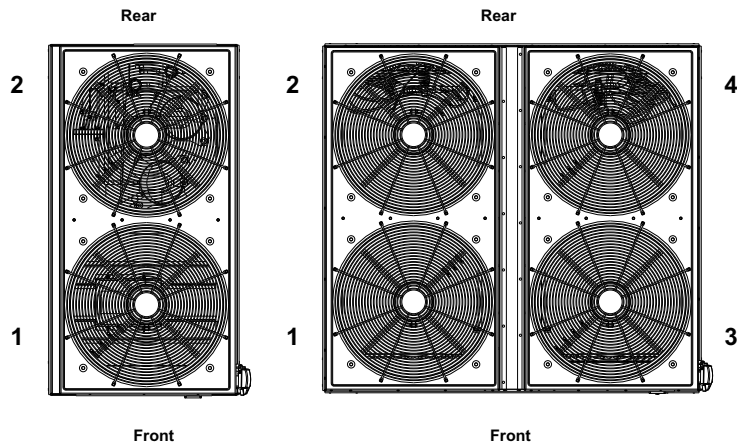


Figure 13: Fan Orientation - Control Box End

Table 10: YC090 thru 300 Unit Control Board Flash Codes

FLASH CODE	DESCRIPTION	GREEN LED 16	RED LED 8	RED LED 4	RED LED 2	RED LED 1
On Steady	This is a Control Failure	-	-	-	-	-
1 Flash	Not Applicable	-	-	-	-	-
2 Flashes	Control waiting ASCD <sup>1</sup>	Flashing	Off	Off	On	Off
3 Flashes	HPS1 Compressor Lockout	Off	Off	Off	On	On
4 Flashes	Not Applicable	-	-	-	-	-
5 Flashes	LPS1 Compressor Lockout	Off	Off	On	Off	On
6 Flashes	Not Applicable	-	-	-	-	-
7 Flashes	FS1 Compressor Lockout <sup>2</sup>	Off	Off	On	On	On
8 Flashes	Not Applicable	-	-	-	-	-
10 Flashes	Compressors Locked Out on Low Outdoor Air Temperature <sup>1</sup>	Flashing	On	Off	On	Off
12 Flashes	Unit Locked Out due to Fan Overload Switch Failure	Off	On	On	Off	Off
13 Flashes	Compressor Held Off due to Low Voltage <sup>1</sup>	Flashing	On	On	Off	On
14 Flashes	EEPROM Storage Failure	Off	On	On	On	Off
OFF	No Power or Control Failure	Off	Off	Off	Off	Off

- 1. Non-alarm condition.
- 2. Freeze Stat not applicable.

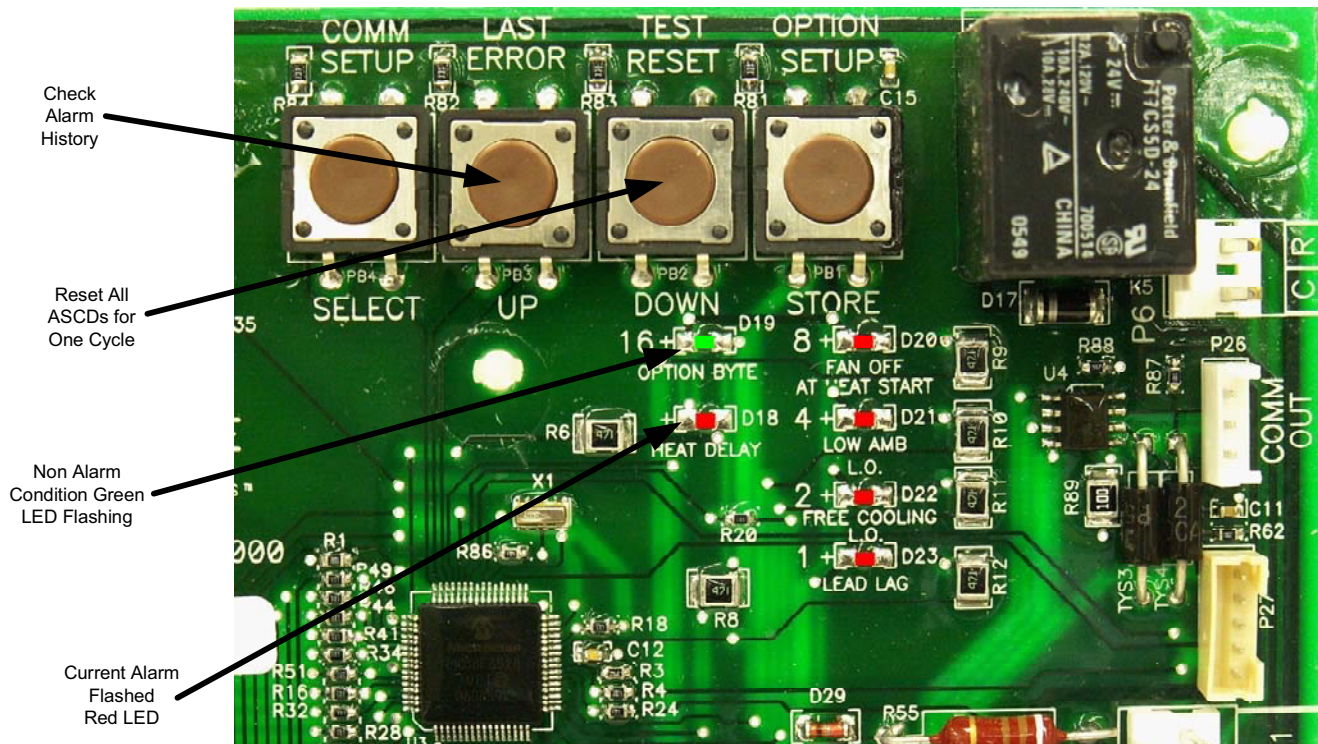
Table 11: YD120 thru 240 Unit Control Board Flash Codes

FLASH CODE	DESCRIPTION	GREEN LED 16	RED LED 8	RED LED 4	RED LED 2	RED LED 1
On Steady	This is a Control Failure	-	-	-	-	-
1 Flash	Not Applicable	-	-	-	-	-
2 Flashes	Control waiting ASCD <sup>1</sup>	Flashing	Off	Off	On	Off
3 Flashes	HPS1 Compressor Lockout	Off	Off	Off	On	On
4 Flashes	HPS2 Compressor Lockout	Off	Off	On	Off	Off
5 Flashes	LPS1 Compressor Lockout	Off	Off	On	Off	On
6 Flashes	LPS2 Compressor Lockout	Off	Off	On	On	Off
7 Flashes	FS1 Compressor Lockout <sup>2</sup>	Off	Off	On	On	On
8 Flashes	FS2 Compressor Lockout <sup>2</sup>	Off	On	Off	Off	Off
10 Flashes	Compressors Locked Out on Low Outdoor Air Temperature <sup>1</sup>	Flashing	On	Off	On	Off
12 Flashes	Unit Locked Out due to Fan Overload Switch Failure	Off	On	On	Off	Off
13 Flashes	Compressor Held Off due to Low Voltage <sup>1</sup>	Flashing	On	On	Off	On
14 Flashes	EEPROM Storage Failure	Off	On	On	On	Off
OFF	No Power or Control Failure	Off	Off	Off	Off	Off

- 1. Non-alarm condition.



2. Freeze Stat not applicable.



**Figure 14: Unit Control Board**

### Flash Codes

Various flash codes are utilized by the unit control board (UCB) to aid in troubleshooting. Flash codes are distinguished by the short on and off cycle used (approximately 200ms on and 200ms off). To show normal operation, the control board flashes a 1 second on, 1 second off "heartbeat" during normal operation. This is to verify that the UCB is functioning correctly. Do not confuse this with an error flash code. To prevent confusion, a 1-flash, flash code is not used.

Alarm condition codes are flashed on the UCB lower left Red LED, See Figure 11. While the alarm code is being flashed, it will also be shown by the other LEDs: lit continuously while the alarm is being flashed. The total of the continuously lit LEDs equates to the number of flashes, and is shown in the table. Pressing and releasing the LAST ERROR button on the UCB can check the alarm history. The UCB will cycle through the last five (5) alarms, most recent to oldest, separating each alarm flash code by approximately 2 seconds. In all cases, a flashing Green LED will be used to indicate non-alarm condition.

In some cases, it may be necessary to "zero" the ASCD for the compressors in order to perform troubleshooting. To reset all ASCDs for one cycle, press and release the UCB TEST/RESET button once.

Flash codes that do and do not represent alarms are listed in Table 14.

### Unit Control Board Option Setup

#### Option Byte Setup

- Enter The Option Setup Mode By Pushing The Option Setup / Store Button, And Holding It For At Least 2 Seconds.
- The Green Status Led (Option Byte) Will Be Turned On And The Red Status Led (Heat Delay) Is Turned Off.
- The 4 Led Will Then Show The Status Of The Labeled Option **Low Ambient Lockout**.
- Press The Up Or Down Button To Change The Led Status To Correspond To The Desired Option Setup.
- To Save The Current Displayed Value, Push The Option Setup / Store Button And Hold It For At Least 2 Seconds. When The Value Is Saved, The Green Led Will Flash A Few Times And Then Normal Display Will Resume.

**NOTE:** While in either Setup mode, if no buttons are pushed for 60 seconds, the display will revert to its normal display, exiting the Option Setup mode. **When saving, the control board only saves the parameters for the currently displayed mode (Option Byte or Heat Delay). (Heat Delay not applicable on these units.)**

## Normal Maintenance

### WARNING

Prior to any of the following maintenance procedures, shut off all power to the unit, to avoid personal injury.

Periodic maintenance consists of changing or cleaning filters and general cleaning of the outdoor coil.

**FILTERS** - Inspect once a month. Replace Disposable or clean Permanent Type as necessary. DO NOT replace Permanent Type with Disposable.

**MOTORS** - Outdoor fan motors are permanently lubricated and require no maintenance.

**OUTDOOR COIL** - Dirt should not be allowed to accumulate on the outdoor coil surface or other parts in the air circuit. Cleaning should be as often as necessary to keep the coil clean. Use a brush, vacuum cleaner attachment, or other suitable means. Be sure that the power to the unit is shut off prior to cleaning.

### CAUTION

Only soap and water can be used to clean microchannel coils. Do not use an acid cleaner.

### CAUTION

Exercise care when cleaning the coil so that the coil fins are not damaged.

Do not permit the hot condenser air discharge to be obstructed by overhanging structures or shrubs.

## Troubleshooting

### WARNING

Troubleshooting of components necessarily requires opening the electrical control box with the power connected to the unit. Use extreme care when working with live circuit! Check the unit nameplate for the correct range before making any connections with line terminals.

### CAUTION

The wire number or color and terminal designations referred to may vary. Check the wiring label inside the control box access panel for the correct wiring.

## Cooling Troubleshooting Guide

On calls for cooling, if the compressors are operating but the supply air blower motor does not energize after a short delay (the room thermostat fan switch is in the "AUTO" position):

1. Turn the thermostat fan switch to the ON position. If the supply air blower motor does not energize, go to Step 3.
2. If the blower motor runs with the fan switch in the ON position but will not run after the first compressor has energized when the fan switch is in the AUTO position, check the room thermostat for contact between R and G in the AUTO position during calls for cooling.
3. If the supply air blower motor does not energize when the fan switch is set to ON, check that line voltage is being supplied to the contacts of the M3, contactor, and that the contactor is pulled in. Check for loose wiring between the contactor and the supply air blower motor.
4. If M3 is pulled in and voltage is supplied to M3, lightly touch the supply air blower motor housing. If it is hot, the motor may be off on internal protection. Cancel any thermostat calls and set the fan switch to AUTO. Wait for the internal overload to reset. Test again when cool.
5. If M3 is not pulled in, check for 24 volts at the M3 coil. If 24 volts are present at M3 but M3 is not pulled in, replace the contactor.
6. Failing the above, if there is line voltage supplied at M3, M3 is pulled in, and the supply air blower motor still does not operate, replace the motor.
7. If 24 volts is not present at M3, check that 24 volts is present at the UCB supply air blower motor terminal, "FAN". If 24 volts is present at the FAN, check for loose wiring between the UCB and M3.
8. If 24 volts is not present at the "FAN" terminal, check for 24 volts from the room thermostat. If 24 volts are not present from the room thermostat, check for the following:
  - a. Proper operation of the room thermostat (contact between R and G with the fan switch in the ON position and in the AUTO position during operation calls).
  - b. Proper wiring between the room thermostat and the UCB, and
  - c. Loose wiring from the room thermostat to the UCB
9. If 24 volts is present at the room thermostat but not at the UCB, check for proper wiring between the thermostat and the UCB, i.e. that the thermostat G terminal is connected to the G terminal of the UCB, and for loose wiring.
10. If the thermostat and UCB are properly wired, replace the UCB.

**On calls for cooling, the supply air blower motor is operating but compressor #1 is not (the room thermostat fan switch is in the "AUTO" position):**

1. If compressor #1 does not energize on a call for cooling, check for line voltage at the compressor contactor, M1, and that the contactor is pulled in. Check for loose wiring between the contactor and the compressor.

2. If M1 is pulled in and voltage is supplied at M1, lightly touch the compressor housing. If it is hot, the compressor may be off on inherent protection. Cancel any calls for cooling and wait for the internal overload to reset. Test again when cool.
  3. If M1 is not pulled in, check for 24 volts at the M1 coil. If 24 volts are present and M1 is not pulled in, replace the contactor.
  4. Failing the above, if voltage is supplied at M1, M1 is pulled in, and the compressor still does not operate, replace the compressor.
  5. If 24 volts is not present at M1, check for 24 volts at the UCB terminal, C1. If 24 volts is present, check for loose wiring between C1 and the compressor contactor.
  6. If 24 volts is not present at the C1 terminal, check for 24 volts from the room thermostat at the UCB Y1 terminal. If 24 volts is not present from the room thermostat, check for the following:
    - a. 24 volts at the thermostat Y1 terminal
    - b. Proper wiring between the room thermostat and the UCB, i.e. Y1 to Y1, Y2 to Y2, and
    - c. Loose wiring from the room thermostat to the UCB
  7. If 24 volts is present at the UCB Y1 terminal, the compressor may be out due to an open high-pressure switch, low-pressure switch, or freezestat. Check for 24 volts at the HPS1, LPS1, and FS1 terminals of the UCB. If a switch has opened, there should be a voltage potential between the UCB terminals, e.g. if LPS1 has opened, there will be a 24-volt potential between the LPS1 terminals.
  8. If 24 volts is present at the UCB Y1 terminal and none of the protection switches have opened, the UCB may have locked out the compressor for repeat trips. The UCB should be flashing an alarm code. If not, press and release the ALARMS button on the UCB. The UCB will flash the last five alarms on the LED. If the compressor is locked out, cancel any call for cooling. This will reset any compressor lock outs.
- NOTE:** While the above step will reset any lockouts, compressor #1 may be held off for the ASCD. See the next step.
9. If 24 volts is present at the UCB Y1 terminal and none of the switches are open and the compressor is not locked out, the UCB may have the compressor in an ASCD. Check the LED for an indication of an ASCD cycle. The ASCD should time out within 5 minutes. Press and release the TEST button to reset all ASCDs.
  10. If 24 volts is present at the UCB Y1 terminal and the compressor is not out due to a protective switch trip, repeat trip lock out, or ASCD, the economizer terminals of the UCB may be improperly wired. Check for 24 volts at the Y1 "OUT" terminal of the UCB. If 24 volts is present, trace the wiring from Y1 "OUT" for incorrect wiring. If 24 volts is not present at the Y1 "OUT" terminal, the UCB must be replaced.
  11. If 24 volts is present at the Y1 OUT terminal, check for 24 volts at the Y1 "ECON" terminal. If 24 volts is not present, check for loose wiring from the Y1 "OUT" terminal to the Mate-N-Lock plug, the jumper in the Mate-N-Lock plug, and in the wiring from the Mate-N-Lock plug to the Y1 "ECON" terminal.
  12. If none of the above corrected the error, test the integrity of the UCB. Disconnect the C1 terminal wire and jumper it to the Y1 terminal. DO NOT jump the Y1 to C1 terminals. If the compressor engages, the UCB has faulted.
  13. If none of the above correct the error, replace the UCB.
- On a call for the second stage of cooling, the supply air blower motor and compressor #1 are operating but compressor #2 is not (the room thermostat fan switch is in the "AUTO" position):**
1. Compressor #2 will not energize simultaneously with compressor #1 if a call for both stages of cooling is received. The UCB delays compressor #2 by 30 seconds to prevent a power surge. If after the delay compressor #2 does not energize on a second stage call for cooling, check for line voltage at the compressor contactor, M2, and that the contactor is pulled in. Check for loose wiring between the contactor and the compressor.
  2. If M2 is pulled in and voltage is supplied at M2, lightly touch the compressor housing. If it is hot, the compressor may be off on inherent protection. Cancel any calls for cooling and wait for the internal overload to reset. Test again when cool.
  3. If M2 is not pulled in, check for 24 volts at the M2 coil. If 24 volts is present and M2 is not pulled in, replace the contactor.
  4. Failing the above, if voltage is supplied at M2, M2 is pulled in, and the compressor still does not operate, replace the compressor.
  5. If 24 volts is not present at M2, check for 24 volts at the UCB terminal, C2. If 24 volts are present, check for loose wiring between C2 and the compressor contactor.
  6. If 24 volts is not present at the C2 terminal, check for 24 volts from the room thermostat at the UCB Y2 terminal. If 24 volts is not present from the room thermostat, check for the following:
    - a. 24 volts at the thermostat Y2 terminal
    - b. Proper wiring between the room thermostat and the UCB, i.e. Y1 to Y1, Y2 to Y2, and
    - c. Loose wiring from the room thermostat to the UCB
  7. If 24 volts is present at the UCB Y2 terminal, the compressor may be out due to an open high-pressure switch, low-pressure switch, or freezestat. Check for 24 volts at the HPS2, LPS2, and FS2 terminals of the UCB. If a switch has opened, there should be a voltage potential between the UCB terminals, e.g. if LPS2 has opened, there will be 24 volts of potential between the LPS2 terminals.
  8. If 24 volts is present at the UCB Y2 terminal and none of the protection switches have opened, the UCB may have locked out the compressor for repeat trips. The UCB

should be flashing a code. If not, press and release the ALARMS button on the UCB. The UCB will flash the last five alarms on the LED. If the compressor is locked out, remove any call for cooling at the thermostat or by disconnecting the thermostat wiring at the Y2 UCB terminal. This will reset any compressor lock outs.

**NOTE:** While the above step will reset any lock outs, compressor #1 will be held off for the ASCD, and compressor #2 may be held off for a portion of the ASCD. See the next step.

9. If 24 volts is present at the UCB Y2 terminal and none of the switches are open and the compressor is not locked out, the UCB may have the compressor in an ASCD. Check the LED for an indication of an ASCD cycle. The ASCD should time out within 5 minutes. Press and release the TEST button to reset all ASCDs.
10. If none of the above corrected the error, test the integrity of the UCB. Disconnect the C2 terminal wire and jumper it to the Y2 terminal. DO NOT jump the Y2 to C2 terminals. If the compressor engages, the UCB has faulted.
11. If none of the above correct the error, replace the UCB.

**On a call for cooling, the supply air blower motor and compressor #2 are operating but compressor #1 is not (the room thermostat fan switch is in the "AUTO" position):**

1. Compressor #2 is energized in place of compressor #1 when compressor #1 is unavailable for cooling calls. Check the UCB for alarms indicating that compressor #1 is locked out. Press and release the ALARMS button if the LED is not flashing an alarm.
2. Check for line voltage at the compressor contactor, M1, and that the contactor is pulled in. Check for loose wiring between the contactor and the compressor.
3. If M1 is pulled in and voltage is supplied at M1, lightly touch the compressor housing. If it is hot, the compressor may be off on inherent protection. Cancel any calls for cooling and wait for the internal overload to reset. Test again when cool.
4. If M1 is not pulled in, check for 24 volts at the M1 coil. If 24 volts is present and M1 is not pulled in, replace the contactor.
5. Failing the above, if voltage is supplied at M1, M1 is pulled in, and the compressor still does not operate, replace the compressor.
6. If 24 volts is not present at M1, check for 24 volts at the UCB terminal, C1. If 24 volts is present, check for loose wiring between C1 and the compressor contactor.
7. If 24 volts is not present at the C1 terminal, check for 24 volts from the room thermostat at the UCB Y1 terminal. If

24 volts are not present at the UCB Y1 terminal, the UCB may have faulted. Check for 24 volts at the Y1 ECON terminal. If 24 volts is not present at Y1 "ECON", the UCB has faulted. The UCB should de-energize all compressors on a loss of call for the first stage of cooling, i.e. a loss if 24 volts at the Y1 terminal.

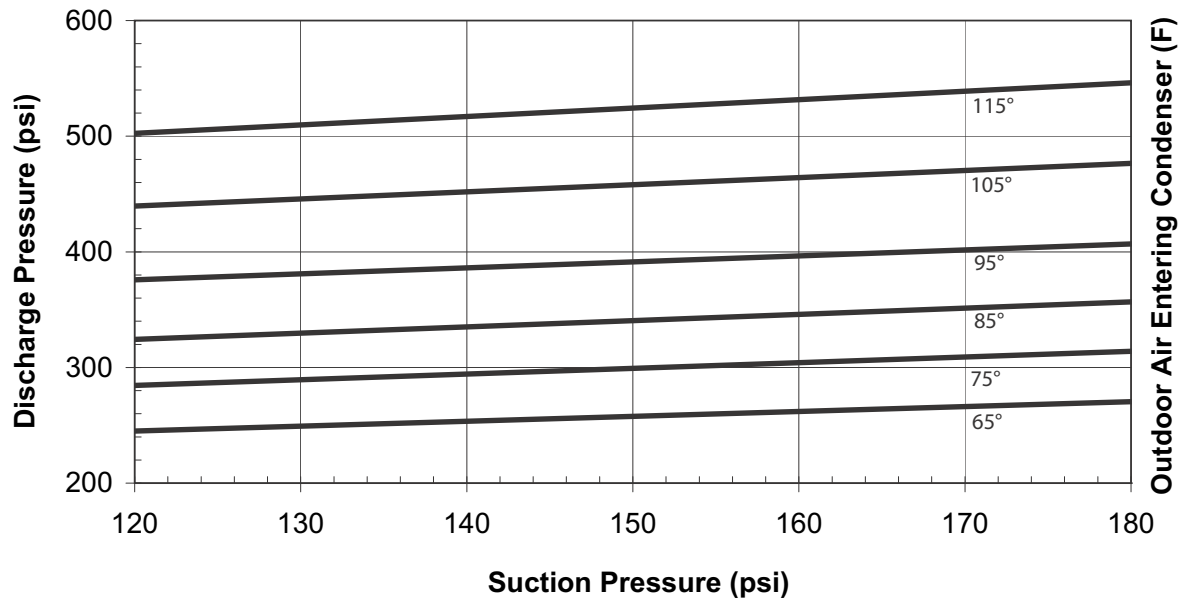
8. If 24 volts are present at the UCB Y1 terminal, the compressor may be out due to an open high-pressure switch, low-pressure switch, or freezestat. Check for 24 volts at the HPS1, LPS1, and FS1 terminals of the UCB. If a switch has opened, there should be a voltage potential between the UCB terminals, e.g. if LPS1 has opened, there will be a 24-volt potential between the LPS1 terminals.
9. If 24 volts is present at the UCB Y1 terminal and none of the protection switches have opened, the UCB may have locked out the compressor for repeat trips. The UCB should be flashing a code. If not, press and release the ALARMS button on the UCB. The UCB will flash the last five alarms on the LED. If the compressor is locked out, remove any call for cooling. This will reset any compressor lock outs.

**NOTE:** While the above step will reset any lock outs, compressor #2 will be held off for the ASCD, and compressor #1 may be held off for a portion of the ASCD. See the next step.

10. If 24 volts is present at the UCB Y1 terminal and none of the switches are open and the compressor is not locked out, the UCB may have the compressor in an ASCD. Check the LED for an indication of an ASCD cycle. The ASCD should time out within 5 minutes. Press and release the TEST button to reset all ASCDs.
11. If 24 volts is present at the UCB Y1 terminal and the compressor is not out due to a protective switch trip, repeat trip lock out, or ASCD, the economizer terminals of the UCB may be improperly wired. Check for 24 volts at the Y1 "OUT" terminal of the UCB. If 24 volts is present, trace the wiring from Y1 "OUT" for incorrect wiring. If 24 volts is not present at the Y1 "OUT" terminal, the UCB must be replaced.
12. If 24 volts is present at the Y1 "OUT" terminal, check for 24 volts at the Y1 "ECON" terminal. If 24 volts is not present, check for loose wiring from the Y1 "OUT" terminal to the Mate-N-Lock plug, the jumper in the Mate-N-Lock plug, and in the wiring from the Mate-N-Lock plug to the Y1 "ECON" terminal.
13. If none of the above corrected the error, test the integrity of the UCB. Disconnect the C1 terminal wire and jumper it to the Y1 terminal. DO NOT jump the Y1 to C1 terminals. If the compressor engages, the UCB has faulted.

If none of the above correct the error, replace the UCB.

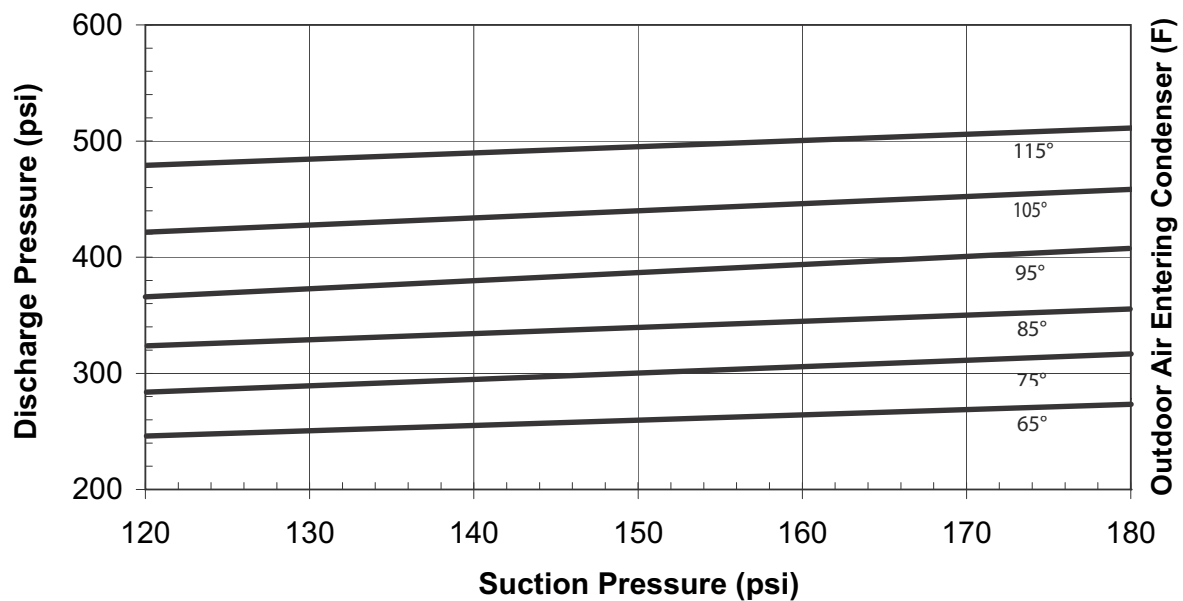
## Charging Curves YC090



1. Make sure that both condenser fans are running when charging.
2. This chart is applicable to unit with the TXV's left to the factory setting. If the TXV's have been adjusted in the field, the charging chart may no longer apply.

Figure 15: YC090 Charging Chart

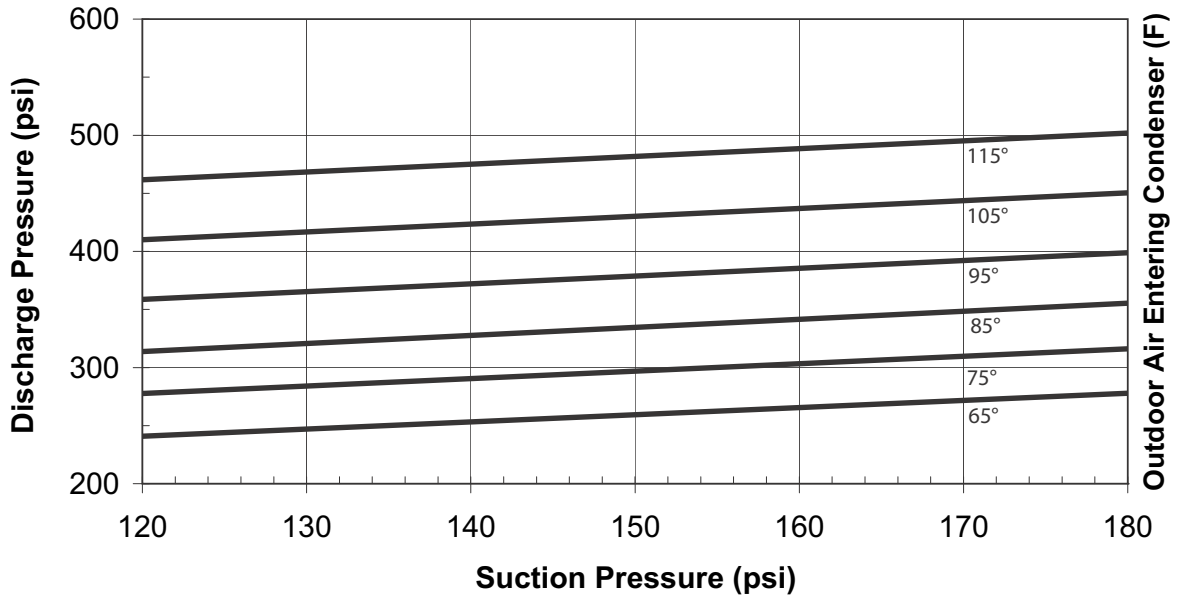
## Charging Curves YC120



1. Make sure that both condenser fans are running when charging.
2. This chart is applicable to unit with the TXV's left to the factory setting. If the TXV's have been adjusted in the field, the charging chart may no longer apply.

Figure 16: YC120 Charging Chart

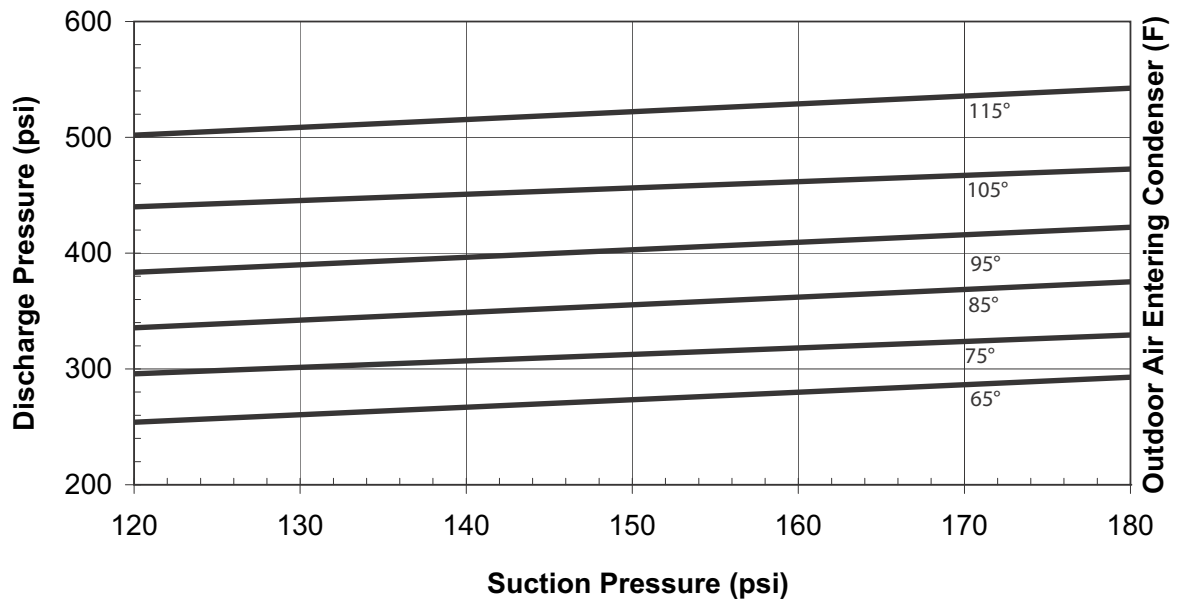
### Charging Curves YD120



1. Make sure that both condenser fans are running when charging.
2. This chart is applicable to unit with the TXV's left to the factory setting. If the TXV's have been adjusted in the field, the charging chart may no longer apply.

Figure 17: YD120 Charging Chart

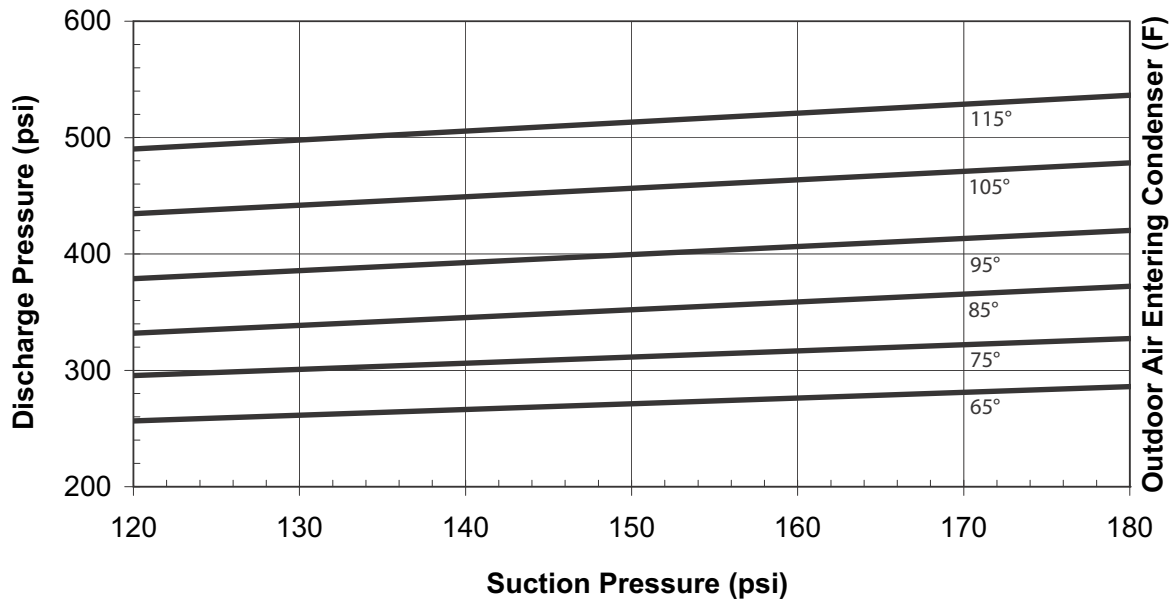
### Charging Curves YC150



1. Make sure that both condenser fans are running when charging.
2. This chart is applicable to unit with the TXV's left to the factory setting. If the TXV's have been adjusted in the field, the charging chart may no longer apply.

Figure 18: YC150 Charging Chart

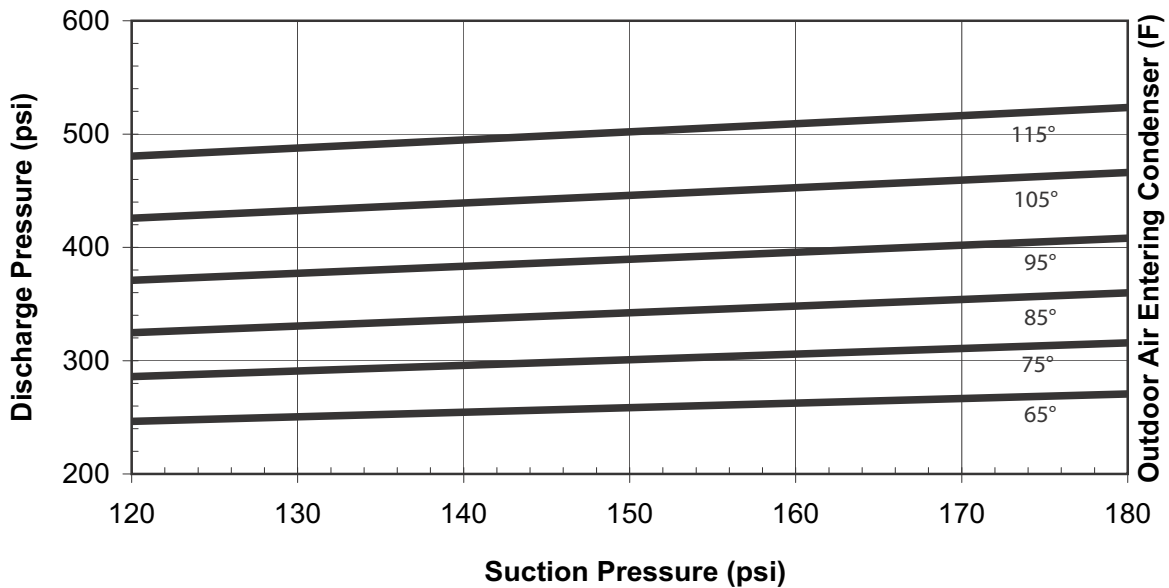
### Charging Curves YD150



1. Make sure that both condenser fans are running when charging.
2. This chart is applicable to unit with the TXV's left to the factory setting. If the TXV's have been adjusted in the field, the charging chart may no longer apply.

Figure 19: YD150 Charging Chart

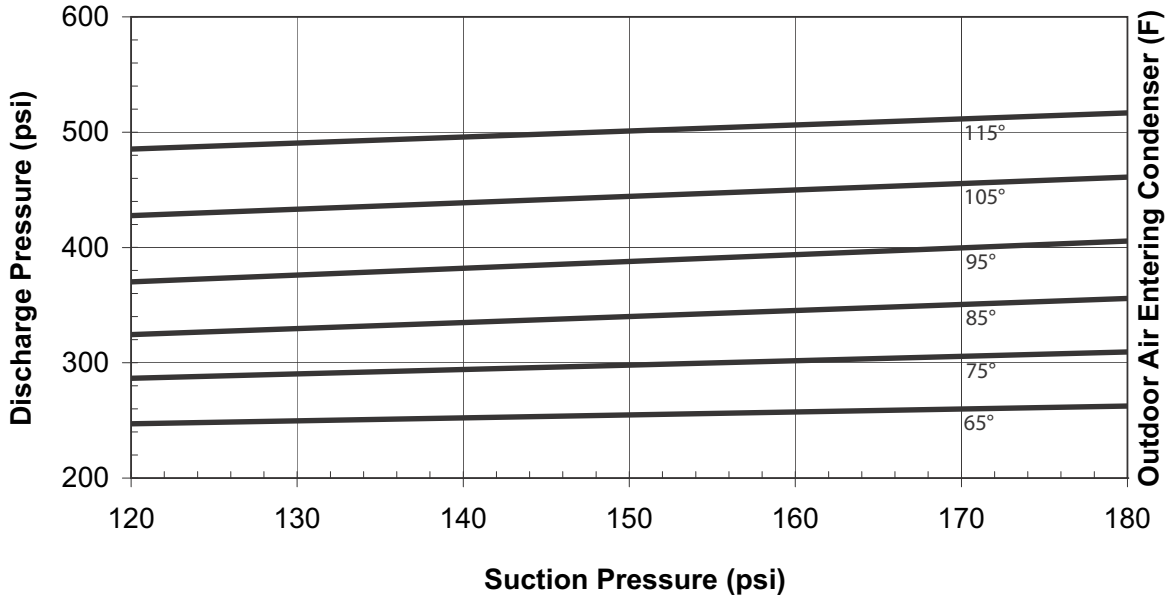
### Charging Curves YC180



1. Make sure that both condenser fans are running when charging.
2. This chart is applicable to unit with the TXV's left to the factory setting. If the TXV's have been adjusted in the field, the charging chart may no longer apply.

Figure 20: YC180 Charging Chart

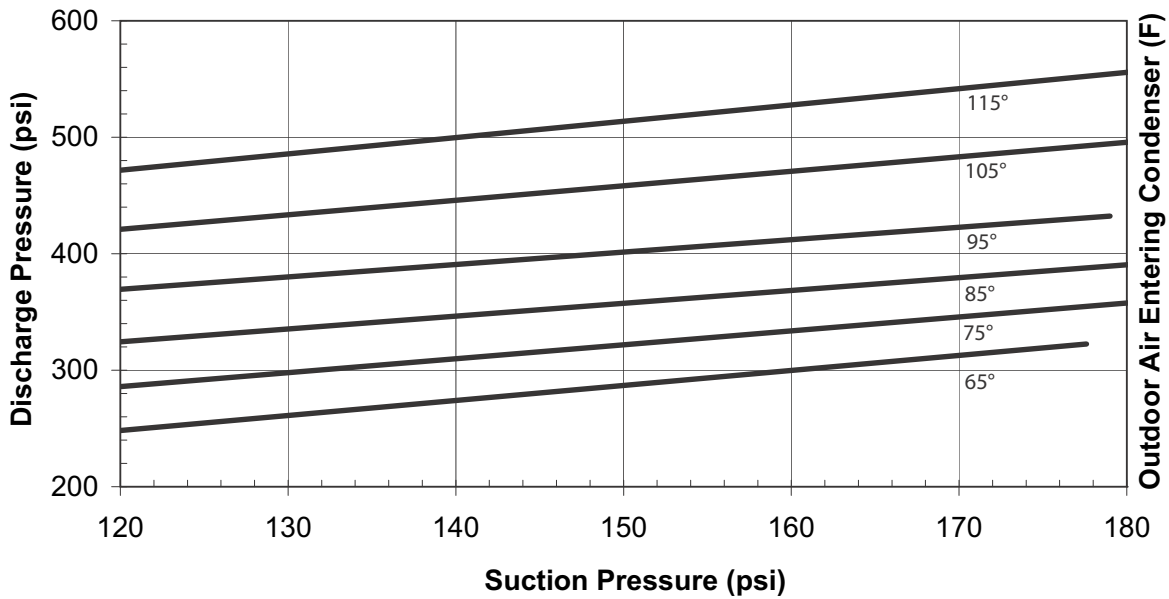
### Charging Curves YD180



1. Make sure that all condenser fans are running when charging.
2. This chart is applicable to unit with the TXV's left to the factory setting. If the TXV's have been adjusted in the field, the charging chart may no longer apply.

Figure 21: YD180 Charging Chart

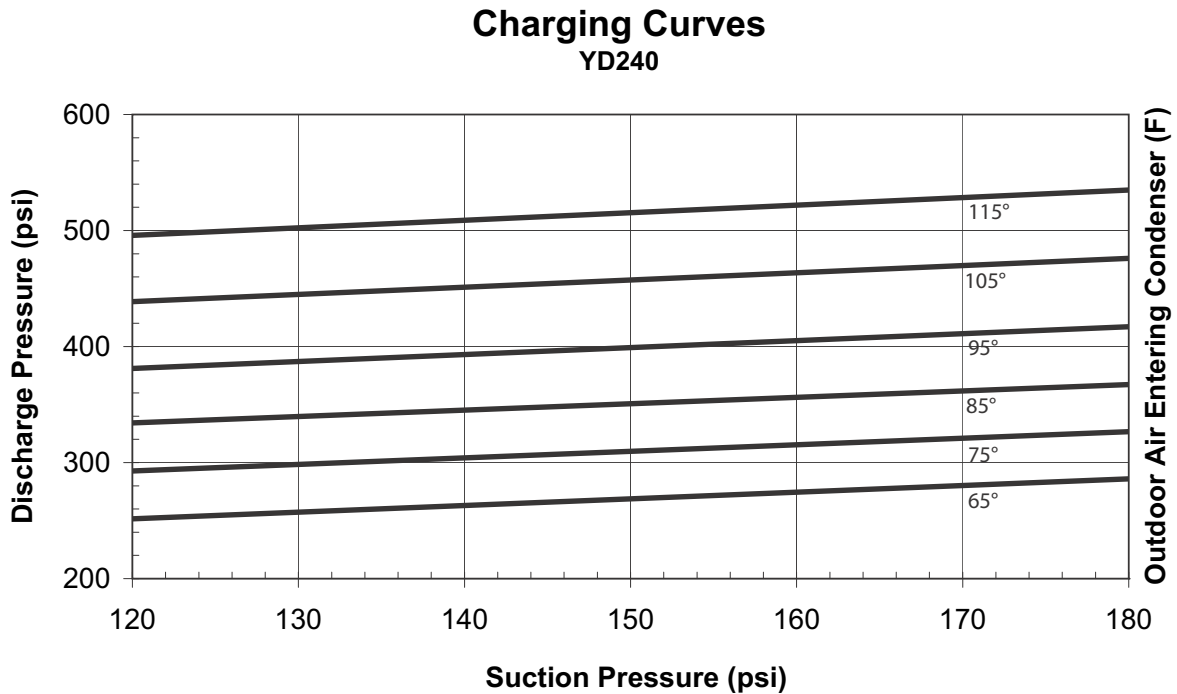
### Charging Curves YC240



1. Make sure that all condenser fans are running when charging.
2. This chart is applicable to unit with the TXV's left to the factory setting. If the TXV's have been adjusted in the field, the charging chart may no longer apply.

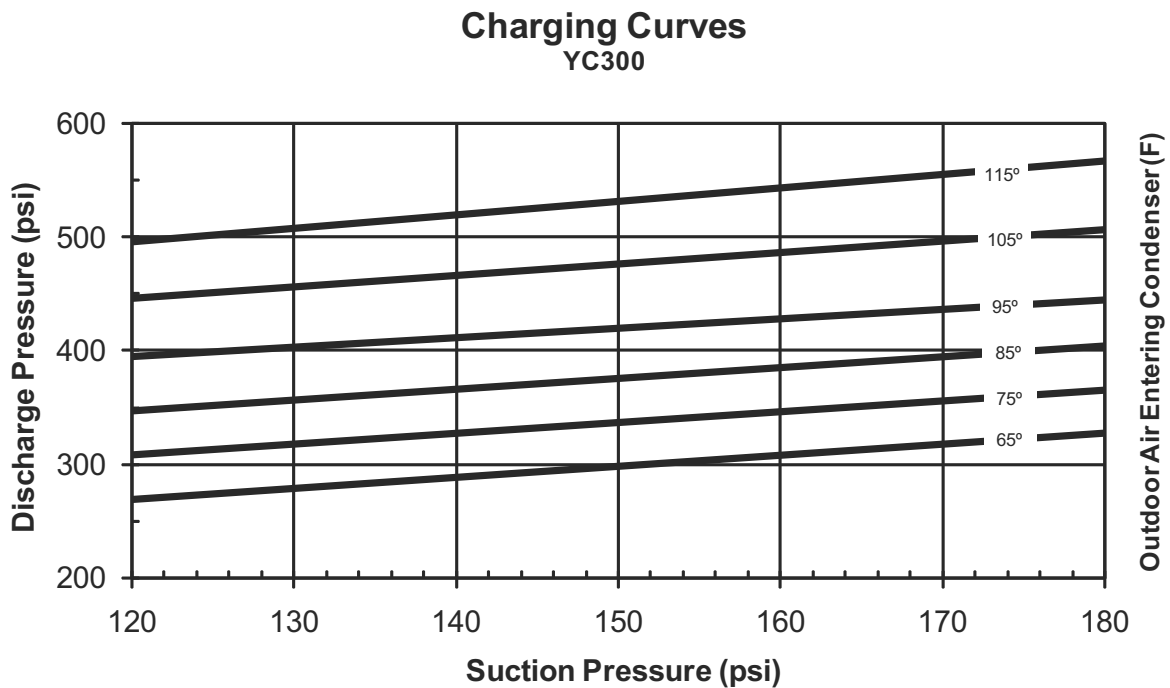
Figure 22: YC240 Charging Chart





1. Make sure that all condenser fans are running when charging.
2. This chart is applicable to unit with the TXV's left to the factory setting. If the TXV's have been adjusted in the field, the charging chart may no longer apply.

Figure 23: YD240 Charging Chart



1. Make sure that both condenser fans are running when charging.
2. This chart is applicable to unit with the TXV's left to the factory setting. If the TXV's have been adjusted in the field, the charging chart may no longer apply.

Figure 24: YC300 Charging Chart

Typical Wiring Diagrams

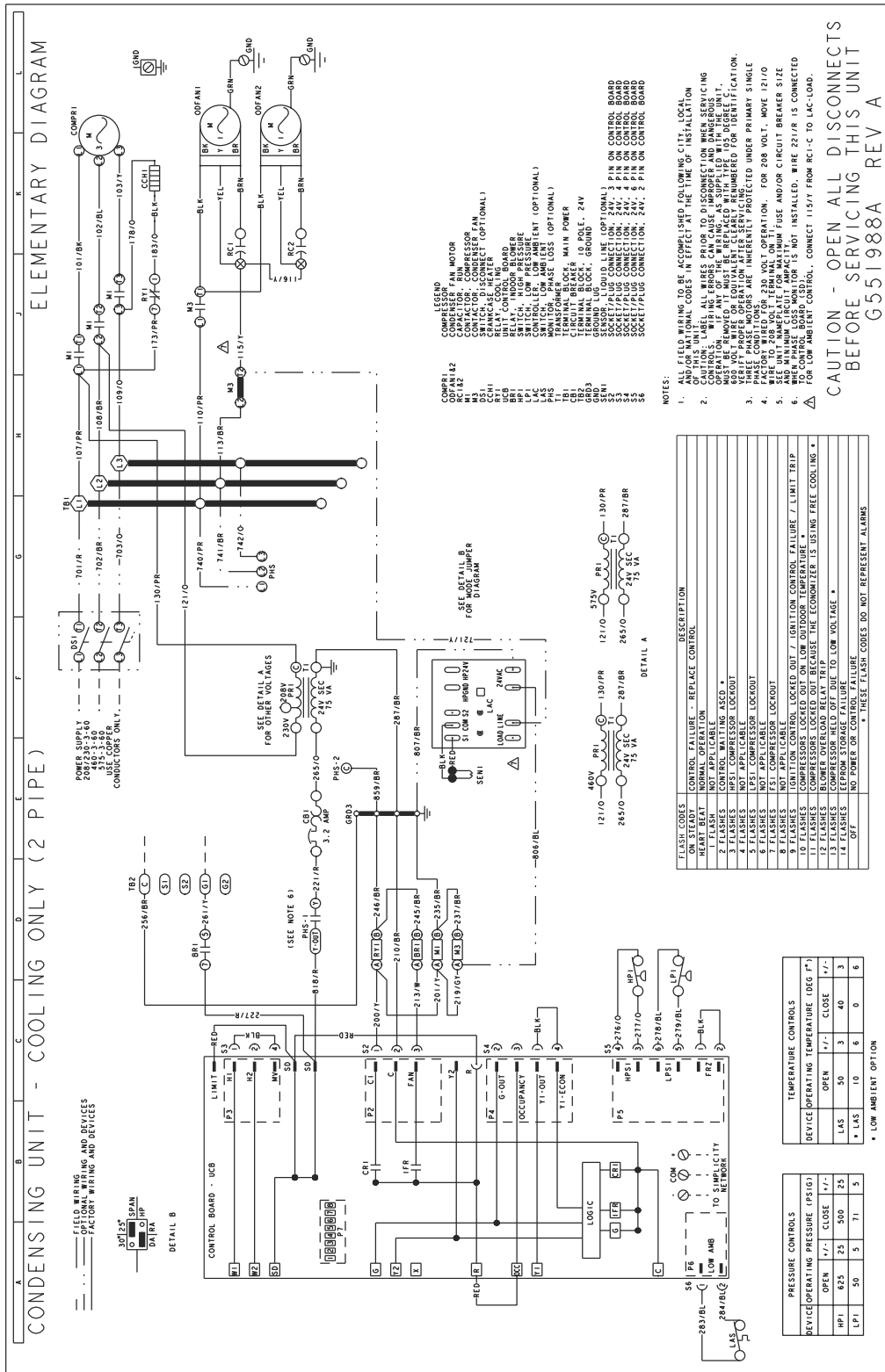
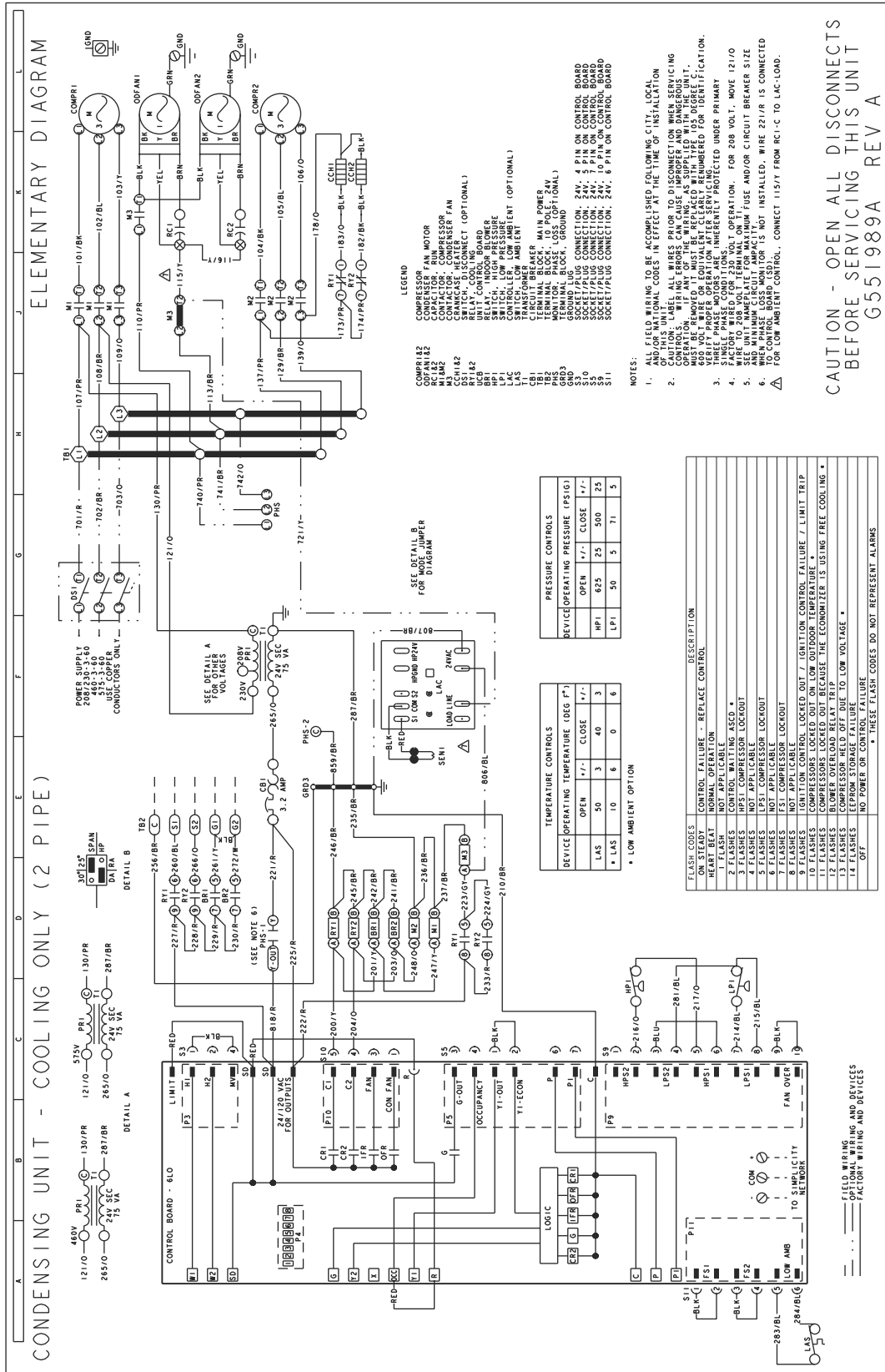
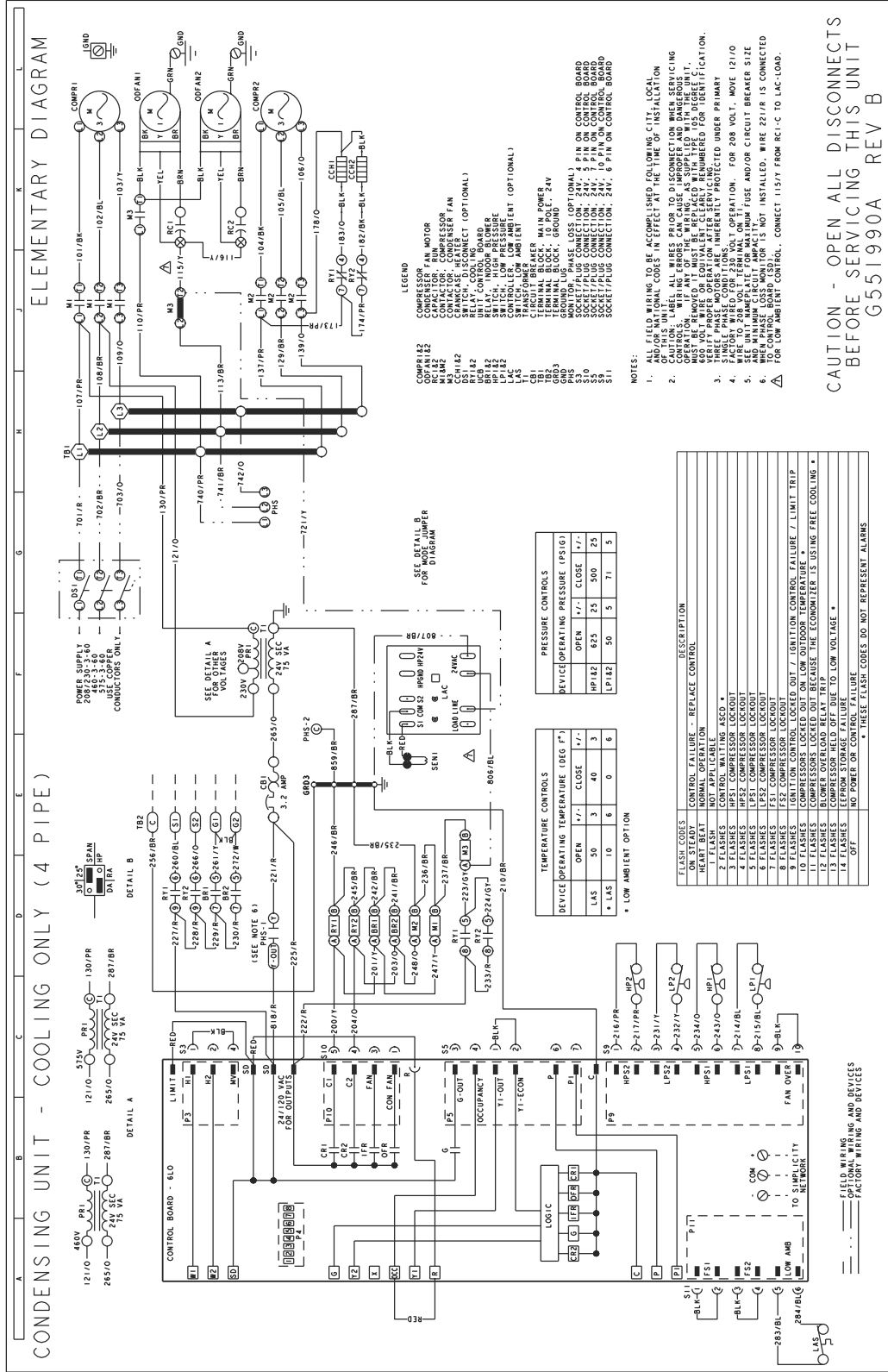


Figure 25: Typical YC090 Condensing Unit Wiring Diagram





CAUTION - OPEN ALL DISCONNECTS BEFORE SERVICING THIS UNIT  
 G51190A REV B

Figure 27: Typical YD120 - 150 Condensing Unit Wiring Diagram



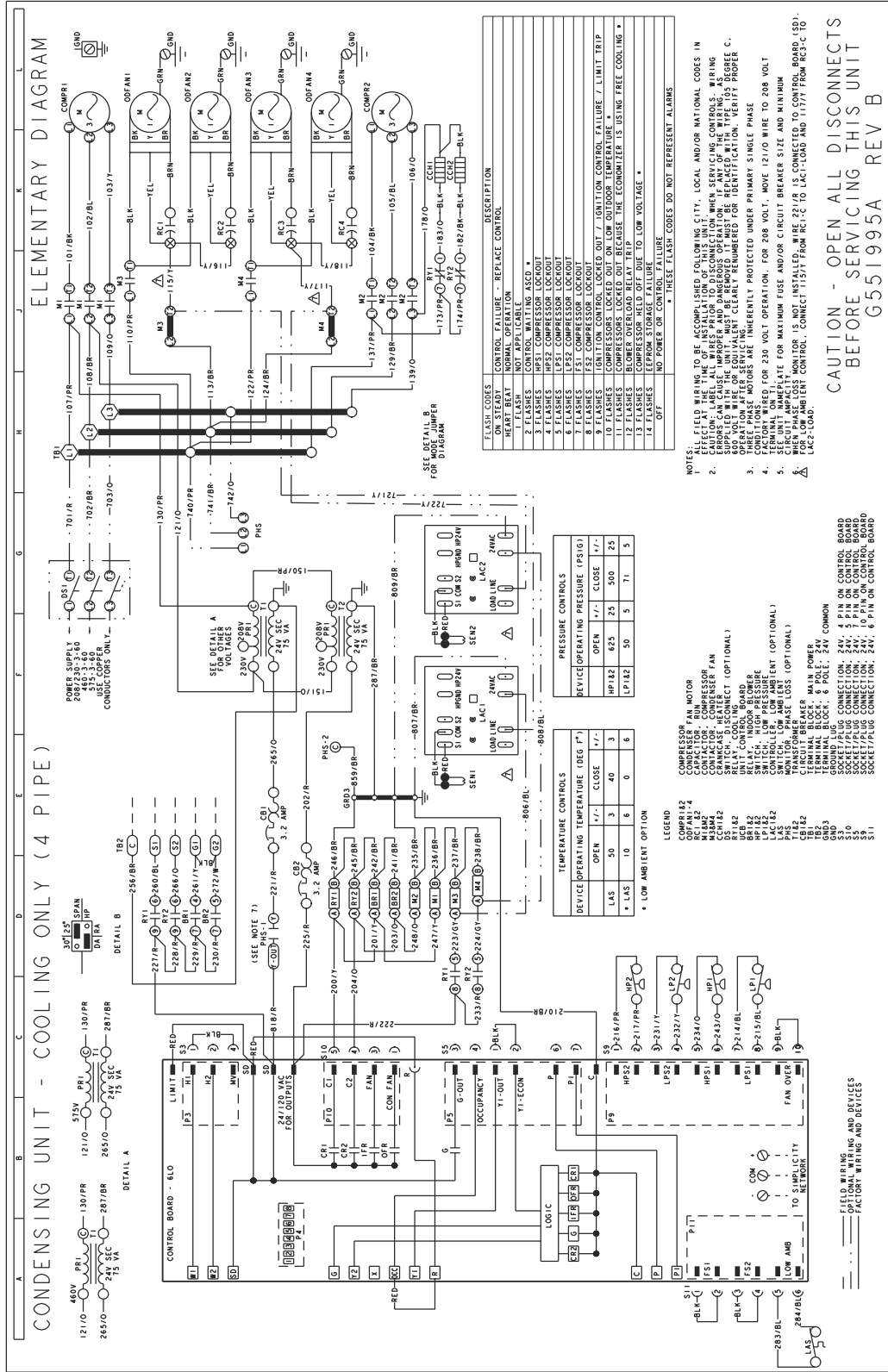


Figure 29: Typical YD180 - 240 Condensing Unit Wiring Diagram



